Users guide for MG-XB

Profibus device with 3...8 digits



- **Panel instrument type MG-BB**
- **Construction instrument type MG-AB**

Contents

1.	Brief description	3
2.	Safety instructions	3
2.1.	Proper use	3
2.2.	Control of the device	3
2.3.	Installation	3
2.4.	Notes on installation	3
3.	Assembly	4
3.1.	Panel instrument MG-BB	4
3.2.	Construction instrument MG-AB (57 mm and 100 mm display height)	5
4.	Electrical connection	6
4.1.	Connection position profibus	6
4.1.1.	Profibus	6
4.2.	Terminal pin assignment power supply for all models	7
4.3.	Position of connection terminals (MG-AB)	7
5.	Operating and display elements	8
6.	Programming	9
6.1.	Programming procedure	9
6.2.	Parameterisation of the Profibus interface	11
7.	Operating modes	12
7.1.	Operating mode 1	12
7.1.1.	Configuration data	12
7.1.2.	Output data	12
7.2.	Operating mode 2	12
7.2.1.	Configuration data	12
7.2.2.	Output data	12
7.3.	Operating mode 3	12
7.3.1.	Configuration data	12
7.3.2.	Output data	12
7.4.	Operating mode 4	13
7.4.1.	Configuration data	13
7.4.2.	Output data	13
7.5.	Operating mode 5	13
7.5.1.	Configuration data	13
7.5.2.	Output data	13
7.6.	Explanation about the panel parameter	14
7.7.	Explanation of the decimal place	14
7.8.	Explanation of the mode	14
7.8.1.	Mode 0	15
7.8.2.	Mode 1	15
8.	Error reports	16
8.1.	Overflow	16
8.2.	Error report	16
9.	Program table	17
10.	Technical data	18

Brief description

1. Brief description

The **MG-XB** is triggered via Profibus. It shows figures/or characters on a 3- up to 8–digit, 7-segment display.

Communication can be controlled via a bus master. The display automatically recognises the baud rate, and the only information it needs is which Profibus address it should use. The **MG-XB** can be parameterised via the display keyboard.

2. Safety instructions

Please read the users guide before installation and keep it for future reference.

2.1. Proper use

The **MG-XB** is intended for displaying figures and characters.



Danger! Careless use or improper operation can result in personal injury and/or damage the equipment.

2.2. Control of the device

The panel meters are checked before dispatch and sent out in perfect condition. Should there be any visible damage, we recommend close examination of the packaging. Please inform the supplier immediately of any damage.

2.3. Installation

The **MG-XB** must be installed by a suitable qualified specialist (e.g. with a qualification in industrial electronics).

2.4. Notes on installation

- There must be no magnetic or electric fields in the vicinity of the device, e.g. due to transformers, mobile phones or electrostatic discharge.
- The fuse rating of the supply voltage should not exceed a value of 6A N.B. fuse.
- Do not install inductive consumers (relays, solenoid valves etc.) near the device and suppress any interference with the aid of RC spark extinguishing combinations or free-wheeling diodes.
- Keep input, output and supply lines separate from one another and do not lay them parallel with each other. Position go and return lines next to one another. Where possible use twisted pair.
- The device is not suitable for installation in areas where there is a risk of explosion.
- Any electrical connection deviating from the connection diagram can endanger human life and/or can destroy the equipment.
- The device must not be mounted in the field of direct solar radiation.
- Do not install several devices immediately above one another. (see ambient temperature in the technical data)

Assembly

3. Assembly

The **MG-XB** is intended for installation in a control panel or as constructive instrument (please indicate which version when ordering).

3.1. Panel instrument **MG-BB**

Before assembly, a cut-out must be made to accommodate the device. The sizes and tolerances are given in the technical data. The device should be installed with the supplied fixtures in line with the drawings.

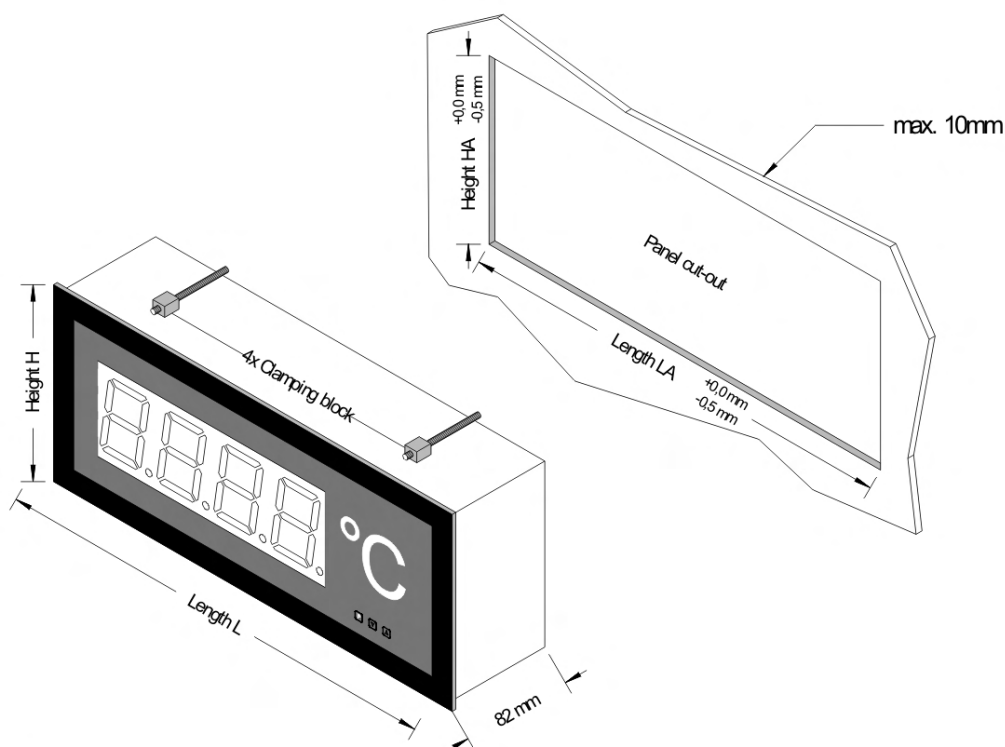

Anzeige 57 mm

Version B

Number of digits	Length L	Length LA	Height H	Height HA
3-digit with dimension	268mm	262mm	124mm	118mm
4-digit with dimension	316mm	310mm		
5-digit with dimension	364mm	358mm		
6-digit with dimension	412mm	406mm		
7-digit with dimension	460mm	454mm		

Version A

Number of digits	Length L	Length LA	Height H	Height HA
3-digit with dimension	288mm	282mm	144mm	138mm
4-digit with dimension	336mm	330mm		
5-digit with dimension	384mm	378mm		
6-digit with dimension	432mm	426mm		
7-digit with dimension	480mm	474mm		

Anzeige 100 mm

Version B

Number of digits	Length L	Length LA	Height H	Height HA
3-digit with dimension	436mm	430mm	176mm	170mm
4-digit with dimension	526mm	520mm		
5-digit with dimension	616mm	610mm		
6-digit with dimension	706mm	700mm		
7-digit with dimension	796mm	790mm		

Version A

Number of digit	Length L	Length LA	Height H	Height HA
3-digit with dimension	460mm	454mm	200mm	194mm
4-digit with dimension	550mm	544mm		
5-digit with dimension	640mm	634mm		
6-digit with dimension	730mm	724mm		
7-digit with dimension	820mm	814mm		

Assembly

3.2. Construction instrument **MG-AB** (57 mm and 100 mm display height)

For fixing of the device, please use the assembly drillings in the fastening angle.

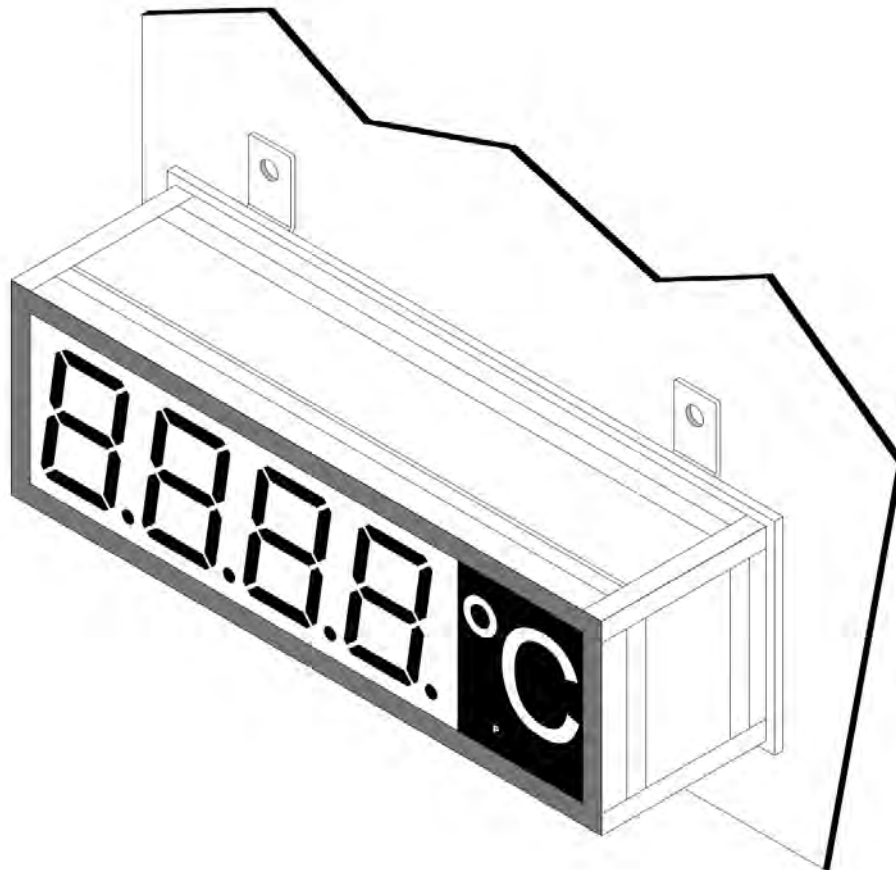

Electrical connection

4. Electrical connection

The electrical connection is made on the rear or the top of the unit.

The electrical connection will depend on which version has been ordered. All the possible connections for the **MG-XB** are described below.

4.1. Connection position profibus

Constructive instrument **MG-AB**

Terminal B (Input)

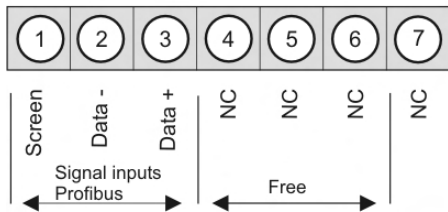

Terminal C (Termination or data output)

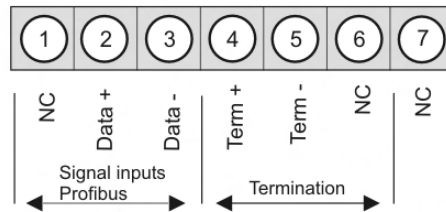

Panel instrument **MG-BB**

Terminal B (Input, output, termination)

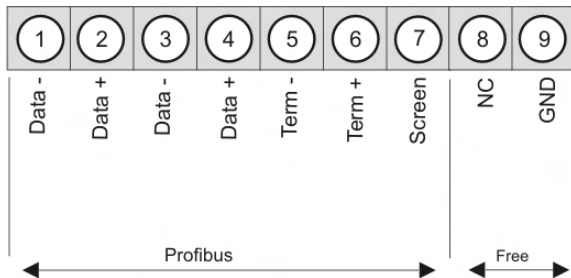

4.1.1. Profibus

In the Profibus, the units are arranged one after the other. A star-shaped configuration is not possible! A termination is needed at both ends of the data line. Any termination existing in the control system must be activated. The maximum permissible length of the data line is 1000 m.

To simplify the connection, the terminals are duplicated. On the last unit of the bus line, the possibility exists of switching the termination to the bus line with two bridges.

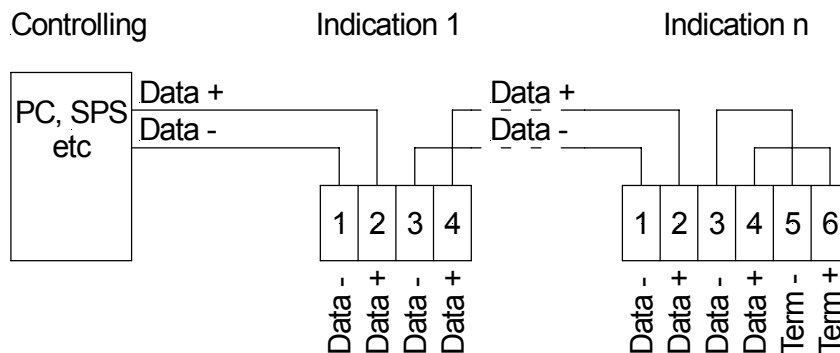

*Connection of several displays to one Profibus – bus line for **MG-BB** devices*

Electrical connection

4.2. Terminal pin assignment power supply for all models

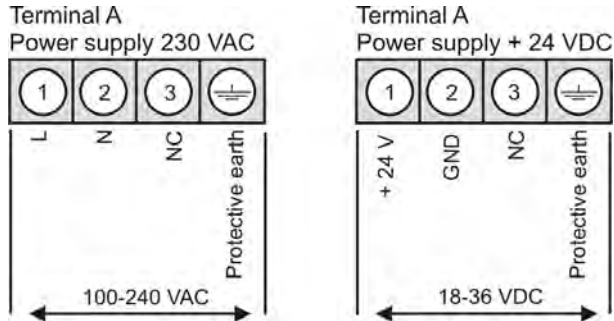

4.3. Position of connection terminals (**MG-AB**)

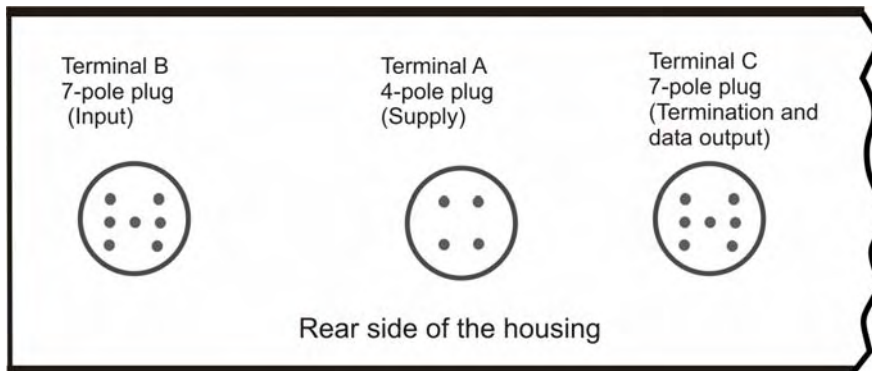

Operation

5. Operating and display elements

The devices are configured via 3 keys; depending on the size of the housing, the unit has a 4-...8-digit 7-segment display.

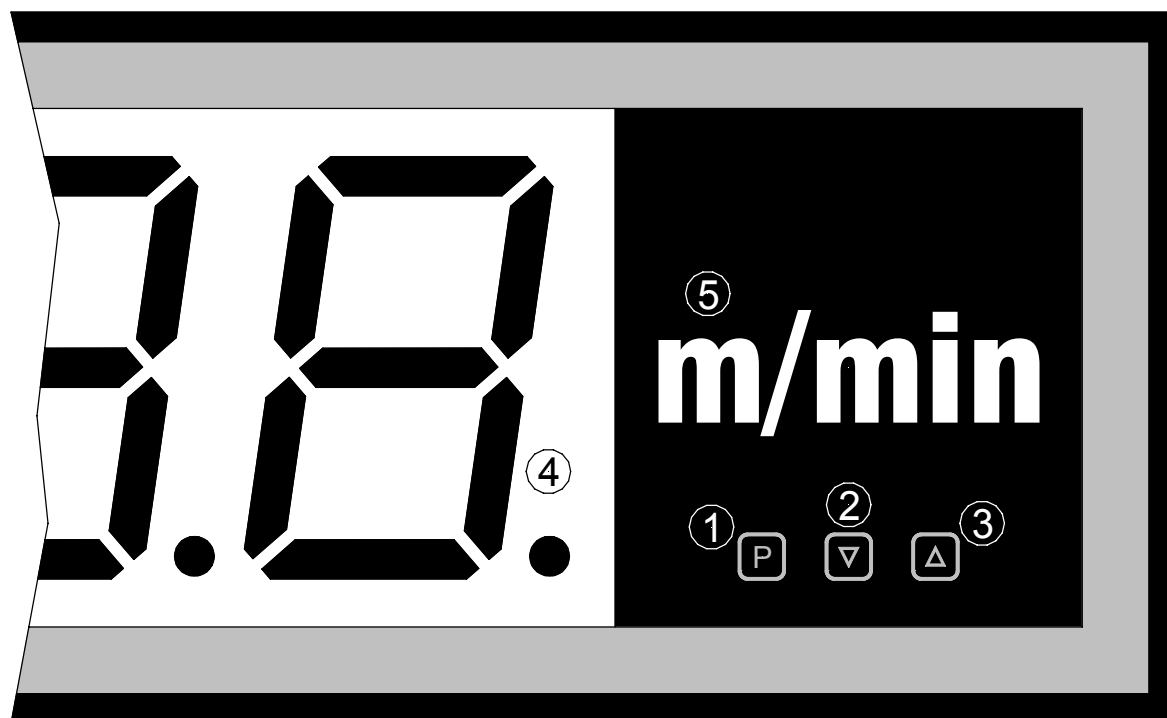

Operating and display elements

- | | | |
|---|--------------------|--|
| 1 | Program key
[P] | With the program key, you can call up the programming mode or perform various functions in the programming mode. |
| 2 | Minus key
[▼] | The minus key is used in programming mode for setting parameters and in operating mode for calling up and erasing error messages. |
| 3 | Plus key
[▲] | The plus key is used in programming mode for setting parameters and in operating mode for calling up and erasing error messages. |
| 4 | 7-segment display | The 7-segment display shows digits/characters as they are received, or, during the programming operation, program numbers or parameters. |
| 5 | Dimension window | Here, a physical unit can be included acc. to the customer's wishes. |

Programming

6. Programming

This section deals with the programming and parameterisation of the **MG-XB**. It also describes the special features and effects of the individual parameters of the program numbers.

The 4-digit display is always used in these examples. The keys are shown below the display, although their position may deviate from this in the actual layout of the unit. If so, you can take the position and function of the keys from *chapter 5. Operating and display elements*.

The display shows the program numbers (PN) right-aligned, as a two-digit number with a **P** at the front.

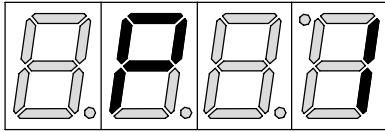

Example: Display of e.g. program number 1

6.1. Programming procedure

The entire programming of the **MG-XB** is done by the steps described below.

Change to programming mode

Pushing the [**P**] key changes to programming mode. The unit goes to the lowest available program number. If the programming lock is activated, the key must be pushed for at least 1 second.

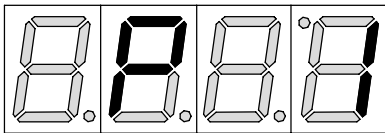

Example:

Change to programming mode by pushing key [**P**]. The first released program number (PN) appears, in this case PN0.

Changing to other program numbers

To change between individual program numbers, hold the [**P**] key down and push the [**▲**] key for changing to a higher program number or the [**▼**] key for changing to a lower number. By keeping the keys pushed, e.g. [**P**] & [**▲**], the display will begin, after approx. 1 second, to automatically run through the program numbers.

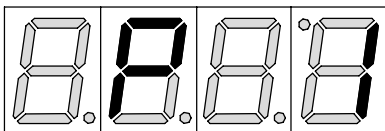

Example:

A 10 is parameterised under PN1. Hold the [**P**] key down and press the [**▲**] several times. After several repeats, PN1 reappears in the display. Under this parameter, the profibus address can be changed.

Change to the parameter

Once the program number appears in the display, you can push the [**▼**] or [**▲**] key to get to the parameters set for this program number. The currently stored parameters are displayed.

Programming

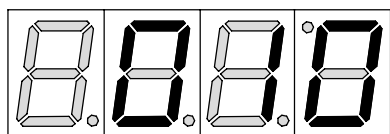

Example:

By pushing the [▼] or [▲] key, the currently stored value for PN1 appears in the display. In this case it is **010**.

Changing a parameter

After changing to the parameter, the lowest digit of the respective parameter flashes on the display. The value can be changed with the [▲] or [▼] key. To move to the next digit, the [P] key must be briefly pushed. Once the highest digit has been set and confirmed with [P], the lowest digit will begin to flash again.

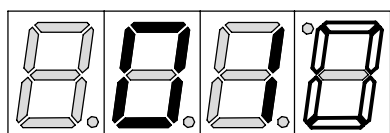

Example:

The **0** is flashing this is the lowest digit and asks if you want to change it. Let us assume the figure is to be changed from **10** to **60**.

Briefly push the [P] key to move to the next digit. The **1** begins to flash. Change the figure by pushing [▲] or [▼]

to change the digit from **1** to **6**. Briefly press the [P] key to move to the next digit. The **0** does not need to be changed.

Saving parameters

All parameters must be acknowledged by the user by pushing the [P] key for one second. The changed parameters are then taken over as the current operating parameters and saved in the EEPROM.

This is confirmed by horizontal bars lighting up in the display.

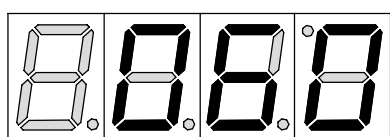

Example:

Save the parameters by pushing [P] for 1 second. All the newly entered data are confirmed by the unit. If no confirmation is received, the relevant parameters have not been saved.

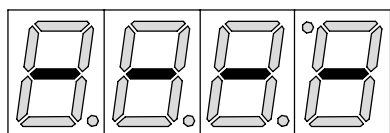

Example:

You receive confirmation from the unit that the changes have been saved through the appearance of horizontal bars in the middle segments.

Change to the operating mode

If no key is pressed in programming mode for approx. 7 seconds, the unit automatically returns to operating mode.

Programming

6.2. Parameterisation of the Profibus interface

Units with a Profibus interface are parameterised via program numbers. The main program numbers are described in detail below. Further information and value ranges are given in the program number table.

Unit address PN1

The unit address can be easily programmed via PN1. The default value here is address 10, which is the factory status. After changing this parameter, the unit performs a soft reset before returning to operating mode. After this, the new address is used immediately.

Default decimal place PN3

If PN3 has been parameterised at > 0 , the decimal place optionally provided by the Profibus is suppressed, and the decimal place requested under PN3 is incorporated.

Watchdog PN4

When $PN4 > 0.0$ the gateway watchdog is activated.

Default brightness PN5

Via the brightness default value, the brightness can be lowered if no brightness level or 100% brightness has been set via the Profibus. The value cannot be altered via the Profibus.

Programming lock PN7

If this parameter is changed so that it no longer conforms to the release code PN8, then all other program numbers are saved. In operating mode, the [P] key must be pressed for at least 1 s in order to call up PN7. The default value and start value for PN7 are always "000". Since PN8 also has a default value of zero, it is possible in this way, by simply changing PN7, to lock the display against inadvertent resetting.

Release code PN8

The release code can be freely selected. This gives the code for which the programming can be released and locked under PN7. The default value has been set at "000". Should the release code become lost, the display can only be made parameterisable again by returning it to the manufacturer.

Operating modes

7. Operating modes

The Profibus displays support 5 different operating modes as described below.

7.1. Operating mode 1

Display of 16-bit signed integers (-32768...32767).

7.1.1. Configuration data

Byte-Nr.	Identification	Description	Function
0	0x21	2 Bytes Output data	Indication value „signed integer“

7.1.2. Output data

Byte-Nr.	Function
0	Indication value high-Byte
1	Indication value low-Byte

7.2. Operating mode 2

Display of 16-bit signed integers (-32768...32767), with brightness control, flashing and decimal place.

7.2.1. Configuration data

Byte-Nr.	Ident	Description	Function
0	0x21	2 Bytes output data	panel parameter (see explanation 7.6)
1	0x20	1 Byte output data	decimal place (see explanation 7.7)
2	0x21	2 Bytes output data	indication value „signed integer“

7.2.2. Output data

Byte-Nr.	Function
0 - 1	Panel parameter (see explanation 7.6)
2	Decimal place (see explanation 7.7)
3	Indication value high-Byte
4	Indication value low-Byte

7.3. Operating mode 3

Display of 32-bit signed integer (-4.294.967.296... 4.294.967.295).

7.3.1. Configuration data

Byte-Nr.	Ident	Description	Function
0	0x23	4 Bytes Output data	Indication value „signed long integer“

7.3.2. Output data

Byte-Nr.	Function
0	Indication value High-Word, High-Byte
1	Indication value High-Word, Low-Byte
2	Indication value Low-Word, High Byte
3	Indication value Low-Word, Low-Byte

Operating modes

7.4. Operating mode 4

Display as 32-bit signed integer (-4.294.967.296...4.294.967.295), with brightness control flashing and decimal place.

7.4.1. Configuration data

Byte-Nr.	Ident	Description	Function
0	0x21	2 Bytes Output data	Panel parameter (see explanation 7.6)
2	0x20	1 Byte Output data	Decimal place (see explanation 7.7)
4	0x23	4 Bytes Output data	Anzeigewert „signed long integer“

7.4.2. Output data

Byte-Nr.	Function
0 - 1	Panel parameter (see explanation 7.6)
2	Decimal point (see explanation 7.7)
3	Indication value High-Word, High-Byte
4	Indication value High-Word, Low-Byte
5	Indication value Low-Word, High-Byte
6	Indication value Low-Word, Low-Byte

7.5. Operating mode 5

Direct display control with brightness control.

7.5.1. Configuration data

Byte-Nr.	Ident	Description	Function
0	0x21	2 Bytes Output data	Panel parameter (see explanation 7.6)
2	0x22	2 Bytes Output data	Mode (see explanation 7.8)
4	0x27	8 Bytes Output data	Direct indication

7.5.2. Output data

Byte-Nr.	Funktion
0 - 1	Panel parameter (see explanation 7.6)
2-3	Modus (see explanation 7.8)
4	1. digit (lowest value display position)
5	2. digit
6	3. digit
7	4. digit
8	5. digit
9	6. digit
10	7. digit
11	8. digit

With 6-digit displays, the first and second places must not be selected (etc.). Nevertheless, all 8 positions must always be transmitted!

Operating modes

7.6. Explanation about the panel parameter

Bit-Nr.	Function
0 - 1*	00 corresponds 100 % brightness 01 corresponds 75 % brightness 10 corresponds 50 % brightness 11 corresponds 25 % brightness
2 - 7	Reserved
8	Flashing 1. digit (lowest value display position)
9	Flashing 2. digit
10	Flashing 3. digit
11	Flashing 4. digit
12	Flashing 5. digit
13	Flashing 6. digit
14	Flashing 7. digit
15	Flashing 8. digit

7.7. Explanation of the decimal place

Bit-Nr.	Function
0 - 2	000 No decimal place 001 1 Decimal place 010 2 Decimal places 011 3 Decimal places 100 4 Decimal places 101 5 Decimal places 110...6 Decimal places 111...7 Decimal places
3 - 6	Reserved
7	0 Indication 1 Display test

7.8. Explanation of the mode

Bit-Nr.	Function
0 - 6	00000000 Display via ASCII-Tabelle (see 7.8.1) 00000001 Direct controlling of the segments (see 7.8.2) 00000010 Reserved ... 01111111 Reserved
7	0 Indication 1 Display test

Operating modes

7.8.1. Mode 0

ASCII-table:

HEX	00	01	02	03	04	05	06	07	08	09	0A	0B	0C	0D	0E	0F
00																
10																
20																
30																
40																
50																
60																
70																

All empty boxes are displayed as blanks.

7.8.2. Mode 1

Direct selection of the segments (bit-coded, all values in hexadecimal form)

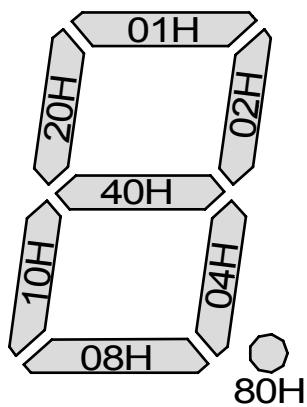

Example:

To depict the character with ASCII code 32H ("2") in mode 1, the value 5BH = (01H + 02H + 40H + 10H + 08H) must be entered in the data field.

Error reports

8. Error reports

The display keeps a watch out for various error possibilities and displays the relevant error message when required.

8.1. Overflow

If a process value (integer) is bigger than the display area, a fast flashing display will appear with the defective value, i.e. with the available significant digits. The minus sign needs a place of its own.

The same happens in mode 5 when segments are selected that do not exist on the display. In this case, the defined display segments flash at high speed.

8.2. Error report

During the start-up process, the configuration is checked. This can result in an error/warning number being read from the gateway. This then reports a check total error, an EEPROM error or a Profibus error.

The unit's processor then begins with the cyclical inquiry of the display segments to be shown that represent the operating mode.

Source of errors	Message	Description
Checksum error	„HLP“	Parameters in the processor not consistent
Gateway error	„Er1“	Gateway does not respond
EEPROM error	„Er2“	Communication error with EEPROM
SPC3 error	„Er3“	Gateway Profibus error
PCHECKSUM error	„Er4“	Gateway check sum of a parameter is incorrect
DATA overflow	„Er5“	Gateway receives too many data
Data exchange error	„Er6“	Profibus master offline
Configuration error	„Er7“	Gateway is working in invalid mode
Watchdog overflow	„Er8“	Watchdog in the gateway has run out

In the case of an initialisation error, the error message appears directly in the display. If there is an operating error, the display responds by flashing the current data quickly for at least 10 seconds.

Any errors that have occurred can be called up by briefly pressing the [▲] or [▼] key and inquiries can be made about the individual errors by briefly pressing these keys several times. Each individual error can be erased by pressing the [▲] or [▼] key for about one second.

If no error has occurred, "noE" will appear. After the error report, the display automatically changes back to operating mode after about 7 seconds.

Program table

9. Program table

The program number table lists all the program numbers (PN) with function, range of values and default values.

PN	Function	Range of values	Default	Res
1	Address	1...126	10	J
3	Default decimal place when PN3 > 0	0...n decimal places	0	N
4	Watchdog in seconds with one decimal place, whereby the watchdog is deactivated at 0.0 seconds.	0,0...65,5	0,0	J
5	Default brightness level when PN5 > 0	0 = 100% 1 = 75% 2 = 50% 3 = 25%	0	N
7	Progammung lock	000...999	000	N
8	Autorisation code	000...999	000	N

n = number of digits – 1 ; position = memory position in the configuration memory; [Res]et after return from programming mode Y/N = Yes/No

Technical data

10. Technical data

**Housing
dimension
Construction
instrument**
(without plug)

Version A

57 mm display 336 x 144 x 82 mm (WxHxD)

100 mm display 550 x 200 x 82 mm (WxHxD)

Version B

57 mm display 316 x 124 x 82 mm (WxHxD)

100 mm display 526 x 176 x 82 mm (WxHxD)

Fixing per fastening angle

Material Aluminium, black, powder-coated

Protective system IP65

Weight

57 mm display approx. 3.0 kg

100 mm display approx. 5.0 kg

Connection

57/100 mm display

Type of plug: Circular plug-in connector Binder-Series 693

Cable admission: PG9 (6.0 to 9.5 mm)

Protection class: IP65

Mechanic life expectancy: > 500 contact durability

Connection type: Screws

Connection

Voltage supply:

Number of poles: 3 + PE

Cable cross section: 0.5 to 2.5 mm (AWG 20...14)

Rating voltage: 400 V

Rating current: 12 A

Connection

Inputs / Outputs:

Number of poles: 7

Cable cross section: 0.34 to 1.5 mm (AWG 22...16)

Rating voltage: 250 V

Rating current: 8 A

Technical data

Dimensions mounting housing (without plug terminals)	Version A	
	57 mm display	W 336 x H 144 x D 82 mm
	100 mm display	W 550 x H 200 x D 82 mm
	Version B	
	57 mm display	W 316 x H 124 x D 82 mm
	100 mm display	W 526 x H 176 x D 82 mm
(with plug terminal)	Version A / B	
	57 mm /100 mm display	W ... x H ... x D 104 mm
Assembly cut-out	Version A	
	57 mm display	330.0 ^{-0.5} x 138.0 ^{-0.5} mm (WxH)
	100 mm display	544.0 ^{-0.5} x 194.0 ^{-0.5} mm (WxH)
	Version B	
	57 mm display	310.0 ^{-0.5} x 118.0 ^{-0.5} mm (WxH)
	100 mm display	520.0 ^{-0.5} x 170.0 ^{-0.5} mm (WxH)
	Weight	
	57 mm display	approx. 3.0 kg
	100 mm display	approx. 5.0 kg
	Connection	
	57/100 mm display	4-pole adaptable screw terminal for in- and output, adapted for line diameter up to 2.5 mm ² . 9-pole adaptable screw terminal for in- and output, adapted for line diameter up to 1.5 mm ² .
Display	Display	7-segment LED
	Digit height	57 mm, 100 mm
	Segment colour	Red (optionally Green)
	Number of places	4...8 digits
	Field of application	Indoor (Outdoor optionally)
Profibus	Protocol	Profibus-DP
	Baud rate	Auto baud recognition up to 12 MBaud
	Interface	RS485
	Cable length	max. 1000 m
	Bus termination	Pull-up/-down to EN50170
	Termination	can be activated via connecting terminal
Power supply	Supply voltage	100-240 VAC nominal voltage +/-10%, 50/60 Hz 18-36 VDC
	Power consumption	max. 30 VA

Technical data

Memory	Parameter memory EEPROM
Data life	>100 year
Ambient conditions	
Working temperature	0...60 °C
Storage temperature	-20...80 °C
Climatic resistance	rel. humidity ≤ 75 % on year average without dew
EMV	DIN 61326
CE-sign	Conformity to 89/336/EWG
Safety standard	DIN 61010