

Temperature metering PT1000 (°C/°F)

- Standard: 2 setpoints, min/max memory
- Mounting into panels with thickness up to 50 mm - optional analogue output

96x48

8888

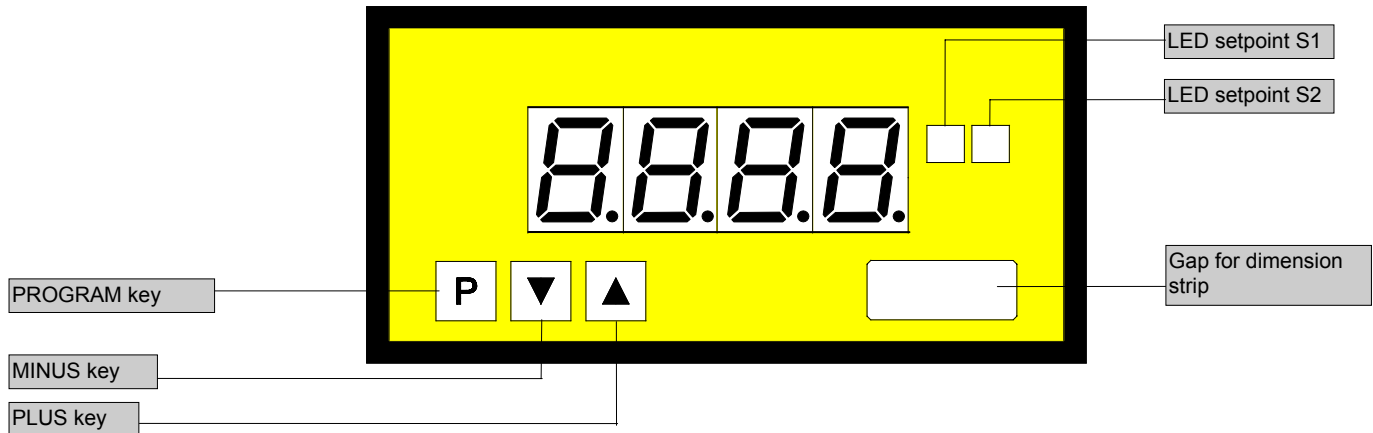

ORDER NUMBER OF TYPE
2 wire **PTE 4.606.1522B (600,0°C)**

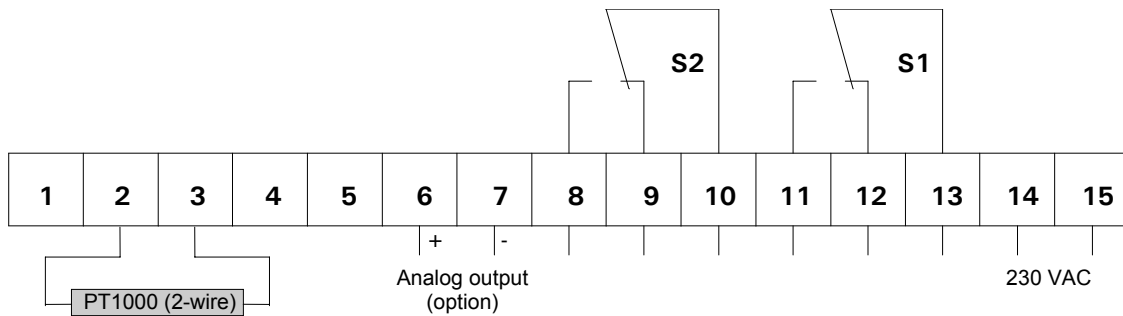

Power supply 115 VAC
(connection via terminal 14 and 15)
2 wire **PTE 4.606.1422B (600,0°C)**

Power supply 24 VDC
galv. insulated - (15=plus, 14=minus)
2 wire **PTE 4.606.1722B (600,0°C)**

Options

- green LED
- Protection IP54
- Protection IP65
- Analog output 0-10 VDC (12 bit)
- Analog output 0-20 mA/load 500 Ω (12 bit)
- Analog output 4-20 mA/load 500 Ω (12 bit)
- Analog output 0-10 VDC (12 bit) *(supply voltage 24 VDC galvanically insulated)*
- Analog output 0-20 mA/load 500 Ω (12 bit) *(supply voltage 24 VDC galvanically insulated)*
- Analog output 4-20 mA/load 500 Ω (12 bit) *(supply voltage 24 VDC galvanically insulated)*
- Other power supplies on demand

Technical data

Dimensions	Housing	96 x 48 x 134 mm, including screw terminal
	Assembly cut out	92.0 ^{+0.8} x 45.0 ^{+0.6} mm
	Fastening	special quick plastic clamp proper to fix in wall thickness up to 50 mm
	Housing material	PC/ABS-plastic blend, colour black, UL94V-0
	Protective system	at the front IP40 connection IP00
	Weight	approx. 0.450 kg
	Connection	at the rear side via screw terminals up to 2.5 mm ²
Input	PT1000	2 wire
	Measuring range	-99.9°C up to +600.0 °C
	Resolution	0.1°C
	Linearization	according to DIN IEC 751
	Sensor current	approx. 0.1 mA
Output	Relay output	charge 230 VAC/5 A – 30 VDC/2 A, with ohm resistive burden
	Switching cycles	0.5 * 10 ⁵ at max. contact rating 5 * 10 ⁶ mechanically
		Separation appropriate to DIN EN 50178/ Specification appropriate to DIN EN60255
	Analogue output	0-10 VDC (12 bit) 0-20 mA (12 bit) - load 500 Ohm 4-20 mA (12 bit) - load 500 Ohm
		} The analogue output is galvanic insulated from the measuring input!
Accuracy	Resolution	0.1°C
	Measuring fault	R _L ≤ 10 Ω = +/-1K R _L > 10 Ω ≤ 20 Ω = +/-2K
	Temp. drift	100 ppm/K
	Measuring principle	voltage/frequency converter
Power unit	Supply voltage	230/115 VAC +/- 10% (50-60 Hz), 24 VDC (+/-10%) galvanic insulated
	Power consumption	approx. 5 VA
Indication	Display	LED with 7 segments, 14 mm high, red 4-digit = indication 9999
	Overflow	indication of 4 transversal bars
	Indication time	from 0.2 up to 10.0 seconds adjustable
Ambient conditions	Working temperature	0 up to + 60°C
	Storing temperature	-20 up to + 80°C
Housing:		

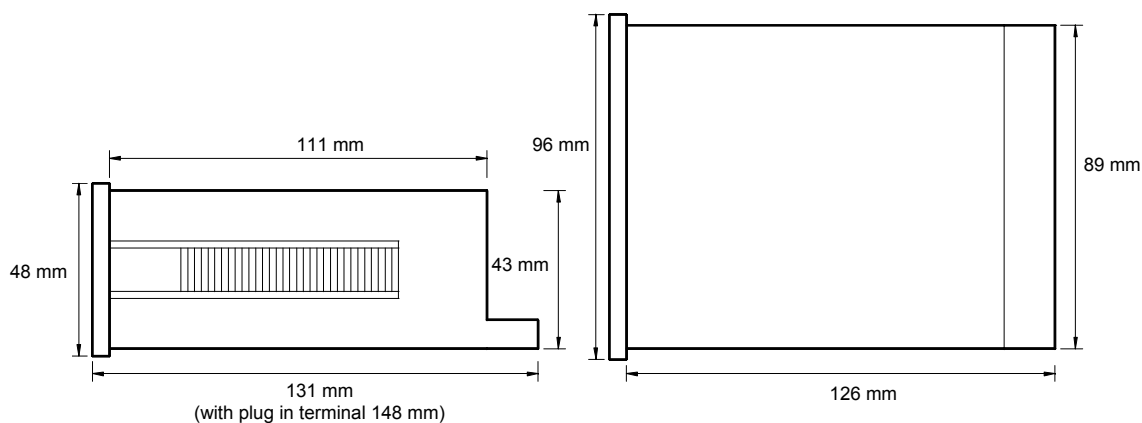

CE-sign

For unlimited use of the instrument within the directives for electromagnetic compatibility 89/336/EC measuring wires have to be used with shielded cable and cable's shield connected to earth ground at one end only.

Connection diagram, programming, remarks

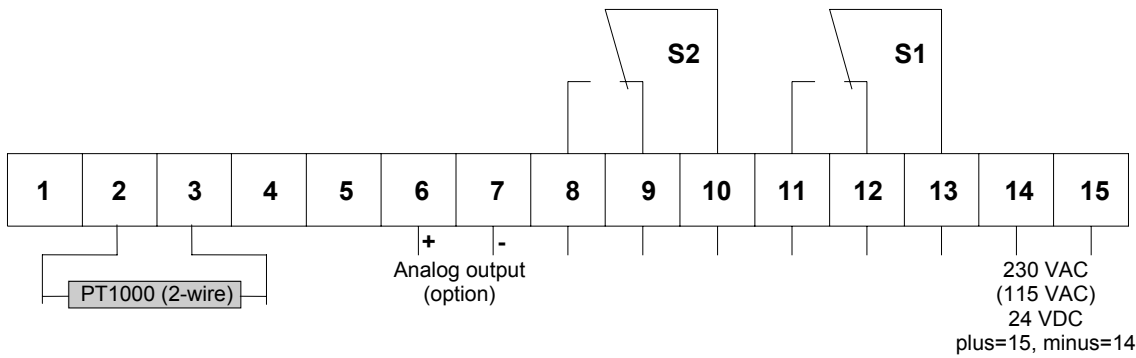

Setting

1. Connect the instrument according to the wiring diagram.
2. After power on, the instrument runs into a lamp test and returns back to the standard mode.
3. Pressing the **P**-key enters the program mode with indication of **P2** on the display.
4. Pressing the **P**-key and **▲**-key simultaneously steps through the different program numbers.
5. Pressing **▲** or **▼**-key shows the current values.
6. To change values use **▲** or **▼**-key.
7. The remaining values will be memorized automatically 7 seconds after the last touch of key with leaving program mode.

Additional key-functions in standard mode for indication of min/max values.

Simultaneously pressing of **▼** and **▲** key deletes and actualizes min/max-memory.
▲ key enters max-memory.
▼ key enters min-memory.

Instructions

After power on the instrument with his inbuilt microcontroller starts with an initial program activating lamp test and readout of memorized parameters in an EEPROM.

The following diagrams are showing the switching operation of PTE4 relay contacts. The hysteresis is free programmable. There are two kinds of operation:

Example: operation current

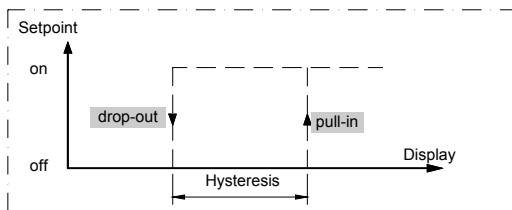

Operation current means that the relay will be pulled in if reaching the adjusted setpoint.

Example: quiescent current

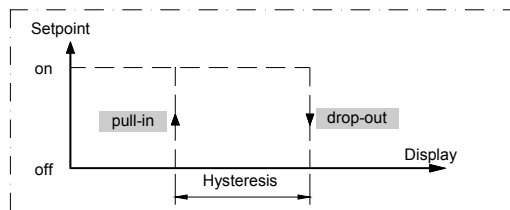

Quiescent current means that the relay will be dropped out if reaching the adjusted setpoint.

Operation, setting instructions

Subject to technical alteration - status 03/2006 – PTE461GB.DOC

Program table 1

Program-Number (PN)	Function	Remark	Display	Basic parameters after reset
2	Sensor and line balancing	Temperature is displayed	0 to +/-20.0	0.0
3	Selection between °C or °F	Celsius = 0 / Fahrenheit = 1	0/1	0
4	Input of display time	Display time = measuring time Method of measurement integrating	0.2 to 10.0 seconds	1.0
5	Input of final value for analog output	Option	-999 to +9999	500.0
6	Input of offset for analog output	Option	-999 to +9999	0.0

Program table 2
(setpoints)

S1 PN	S2 PN	Function	Display	Basic parameters after reset
61	66	Setpoint	-999 to +9999	100.0/150.0
62	67	Hysteresis	0 to +9999	0.1/0.1
63	68	Quiescent current	0	-
		Operating current	1	1/1

Example for programming

Temperature sensor: PT1000
Connection: 2-wire
Display: 0.0 to 600.0°C
Display refresh time: 2.0 seconds
Setpoints:
 S1 ==> 60.0 and quiescent current
 relay pull in = 58.0 ==>hysteresis 2.0
 S2 ==> 150.0 and operation current
 relay drop out = 80.0 ==>hysteresis 70.0

Analog output:
 0 V output ==> display 0.0 ==> 0.0°C
 10 V output ==> display 600.0 ==> 600.0°C

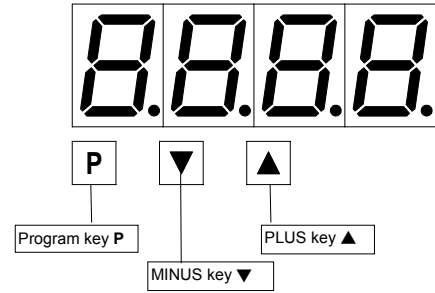

The basic adjustments concerning to the following program example are the ground parameters after a total reset occurring through a power on with pressing P-key (see previous page).

Program advices:

Pressing the P-key enters **always** the program-mode with program number 2. The P2 starts to blink in change with the current value after 3 seconds. After further 4 seconds the system leaves the program mode and goes to the standard mode. In program mode pressing ▼ or ▲ -key selects the current values which are free scalable with both the keys. All the other parameters will be memorized automatically after leaving program mode.

Programming.
Switch power on!

Lamp test



Standard mode

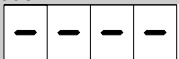

Set PT1000 Simulator to 0°C.
The indication value depends on the used cable length.

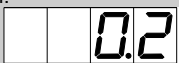

To program number 2 with P.



To memorized value with ▼ or ▲.

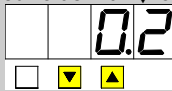

Sensor and line balancing.



To program number 3 with P and ▲.

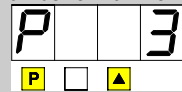

To memorized value with ▼ or ▲.

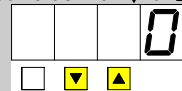

To program number 4 with P and ▲.

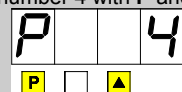

Example for programming

To memorized value with ▼ or ▲.

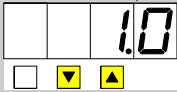

Set display time.

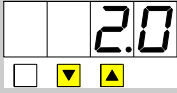

The following programming steps are necessary for the setpoint-programming of S1 and S2 only.

To program number 61 with P and ▲.

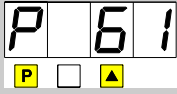

To memorized value with ▼ or ▲.

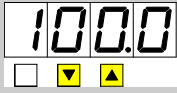

Set free scalable value for setpoint S1.



To program number 62 with P and ▲.

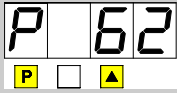

To memorized value with ▼ or ▲.

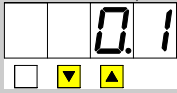

Set hysteresis for S1.

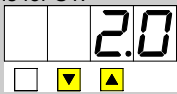

To program number 63 with P and ▲.



To memorized value with ▼ or ▲.

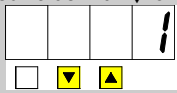

Set quiescent current.

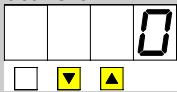

To program number 66 with P and ▲.



To memorized value with ▼ or ▲.



Set free scalable value for setpoint S2.



To program number 67 with P and ▲.



To memorized value with ▼ or ▲.



Set hysteresis for S2.



To program number 68 with P and ▲.



To memorized value with ▼ or ▲.

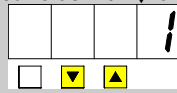

Set operating current.

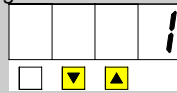

Programming finished.

All programmed values are memorized after 7 seconds. Jumps back into standard mode automatically.

The program numbers 5 and 6 are available with option analogue output only.

To program number 5 with P and ▲.

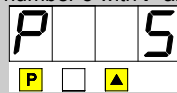

To memorized value with ▼ or ▲.

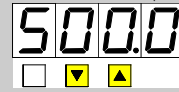

Set free scalable final indication value for analog output.

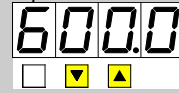

To program number 6 with P and ▲.

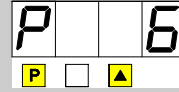

To memorized value with ▼ or ▲.

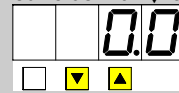

Programming finished

All programmed values are memorized after 7 seconds. Jumps back into standard mode automatically.

Setting possibilities of the jumper field on the rear side.

