User manual for PZ5 devices

Digital processor controlled arithmetic panel meter:

Two voltage/current inputs:

$$x = (In1 + In2) * K$$

$$x = (In1 - In2) * K$$

$$x = (In1 * In2) * K$$

$$x = (In1 / In2) * K$$

$$x = (In1 * 100 / In2) * K$$



Technical features:

- red 5-digit display (-9999...99999)
- min/max value recording
- 30 points linearisation per channel
- permanent cable breakage monitoring
- optical switching point display
- Hold-function/Tara-function via keypad or digital input
- configurable channel switching

Contents

1.	Identification	2
2.	Technical data	3
3.	Safety advices	5
4.	Assembly	6
5.	Electrical connection	7
6.	Operation and function description	10
	6.1 Operation	10
	6.2 Alarms / Relay	13
	6.3 Analog output	15
	6.4 Digital input / Zero-key	15
	6.4.1 Hold-Function	15
	6.4.2 Tara-Function	16
	6.4.3 Configurable channel switching	16
	6.5 Interface RS232 / RS485	16
7.	Programming	17
8.	Program number description	22
	8.1 Program number table	26
9.	Reset to default values	30
10.	Error elimination	31

1. Identification

STANDARD TYPES	ORDER NUMBER
Supply 100-240 VAC 50/60 Hz, DC $\pm 10\%$	PZ5.0301.1S70D
Supply 10-40 VDC, galv. isolated, 18-30 VAC 50/60 Hz	PZ5.0301.1W70D

Options – decoding of the ordering code:

	P	Z	5.	0	3	0	1.	1	S	7	0	D	
Standard device type													
Two standard signal inputs		Z											Internal Index D Version D
Number of digits 5-digit			5										Switching points 0 no switching point 2 2 relay outputs 4 4 relay outputs
Interface none RS232 (galv. isolated) RS485 /galv. isolated)													Mechanical options 7 IP65, foil keypad, plug-in terminal
Sensur supply 24 V / 50 mA													Voltage supply S 100-240 VAC W 10-40 VDC
Outputs none 0-10 V, 0-20 mA, 4-20 mA													Housing size 1 96x48 mm
													Measuring input 1 0-10 VDC, 0/4-20 mA

Dimension signs on demand, please state with order, e.g. m/min.

2. Technical data

Housing	
Dimensions	96x48x120 mm (BxHxD)
	96x48x139 mm (BxHxD) including plug-in terminal
Panel cut-out	92.0 ^{+0.8} x 45.0 ^{+0.6} mm
Wall thickness	up to 15 mm
Fixing	screw elements
Material	PC Polycarbonate, black, UL94V-0
Protection class	standard IP65 (Front), IP00 (Back side)
Weight	approx. 350 g
Connection	Screw clamp/plug-in terminal; line cross section up to 2.5 mm ²
Display	
Digit height	14 mm
Segment colour	red
Range of display	-9999 to 99999
Switching points	1 LED per switching point
Overflow	horizontal bars at the top
Underflow	horizontal bars at the bottom
Display time	0.1 to 10 seconds
Input	
Measuring range	0...10 V and 0/4...20 mA
Input resistance	0...10 V $R_i = \sim 150 \text{ k}\Omega$
	0/4...20 mA $R_i = \sim 50 \Omega$
Measuring error at measuring time = 1 sec	0.02 % of measuring range $\pm 1 \text{ Digit } T_U = 20...40^\circ\text{C}$
Temperature drift at $T_U < 20^\circ\text{C}$ bzw. $> 40^\circ\text{C}$	all measuring inputs 50 ppm/K
Measuring time	1 channel 0.02 ... 10.00 seconds 2 channels 0.04 ... 10.00 seconds
Measuring principle	Sigma / Delta
Resolution	24 bit
Digital input	<2.4 V OFF, >19 V ON, max. 30 VDC, $R_i \sim 5 \text{ k}\Omega$

Output	
Relay	Switch-over contact 230 VAC / 5 A; 30 VDC / 2 A at ohm resistive load
Switching cycles	0.5 * 10 ⁵ at max. contact load 5 * 10 ⁶ mechanically Separation as per DIN EN 50178 / characteristic data as per DIN EN 60255
Output	
Analog output	0/4-20 mA / load ≤ 500 Ω 0-10 VDC / load ≥ 10 kΩ, 16 bit
Error	0.1 % % in the range TU= 20...40°C, beyond 50 ppm/K
Sensor supply (galv. isolated)	24 VDC, 50 mA
Interface	
Protocol	manufacturer-specific ASCII
RS232 (optional galv.isolated)	9600 Baud, no parity, 8 databits, 1 stopbit , ASCII protocol
Lead length	max. 3 m
RS485 (galv. isolated)	9600 Baud, no parity, 8 databits, 1 stopbit , ASCII protocol
Lead length	max. 1000 m
Power Pack	
Supply voltage	100-240 VAC / 50/60 Hz, DC ±10 % (max. 15 VA) 10-40 VDC, galv. isolated, 18-30 VAC 50/60 Hz (max. 15 VA)
Memory	
Parameter memory	EEPROM
Data life	≥ 100 years at 25°C
Ambient conditions	
Working temperature	0...50°C
Storing temperature	-20...80°C
Climatic density	rel. humidity ≤75 % on years average without dew
EMV	
	DIN 61326
CE-sign	
	conformity to directive 2004/108/EG
Safety standard	
	according to low voltage directive 2006/95/EG, EN 61010, EN 60664-1

3. Safety advices

Please read the users guide and *chapter 4* before installation and keep it for future reference.

Proper use

The **PZ5** is designed for the evaluation and presentation of transmitter signals (standard signals). With the set points, it is possible to perform simple control tasks .



Caution! Careless use or improper operation can result in personal injury and/or damage of the equipment!

Control of the device

The panel meters are checked before dispatch and sent out in perfect condition. Should there be any visible damage, we recommend close examination of the packaging. Please inform the supplier immediately of any damage .

Installation

The **PZ5** must be installed by a suitably **qualified specialist** (e.g. with a qualification in industrial electronics).

Notes on installation

- There must be no magnetic or electric fields in the vicinity of the device, e.g. due to transformers, mobile phones or electrostatic discharge.
- **The fuse rating of the supply voltage should not exceed a value of 0.5A N.B. fuse!**
- Do not install **inductive consumers** (relays, solenoid valves etc.) near the device and **suppress** any interference with the aid of RC spark extinguishing combinations or free-wheeling diodes.
- Keep input, output and supply lines separate from one another and do not lay them parallel with each other. Position “go” and “return lines” next to one another. Where possible use twisted pair. This way, the best measuring results will be received.
- Screen off and twist sensor lines. Do not lay current-carrying lines in the vicinity. Connect the **screening on one side** on a suitable potential equaliser (normally signal ground).
- The device is not suitable for installation in areas where there is a risk of explosion.
- Any electrical connection deviating from the connection diagram can endanger human life and/or can destroy the equipment.
- Do not install several devices immediately above one another or in an extremely thermal isolated housing. Due to the internal heat dissipation of the decives, the recommended ambient temperature can be exceeded.
- The terminal area of the device is part of the service. Here electrostatic discharge needs to be avoided. Attention! High voltages can cause dangerous body currents.
- Galvanic isolated potentials within one complex need to be placed on an appropriate point (normally earth or machines ground). So, a lower disturbance sensibility against impacted energy can be reached and dangerous potentials, that can occur on long lines or due to faulty wiring, can be avoided.

4. Assembly

Please read the *Safety advices* on *page 5* before installation and keep this user manual for future reference.

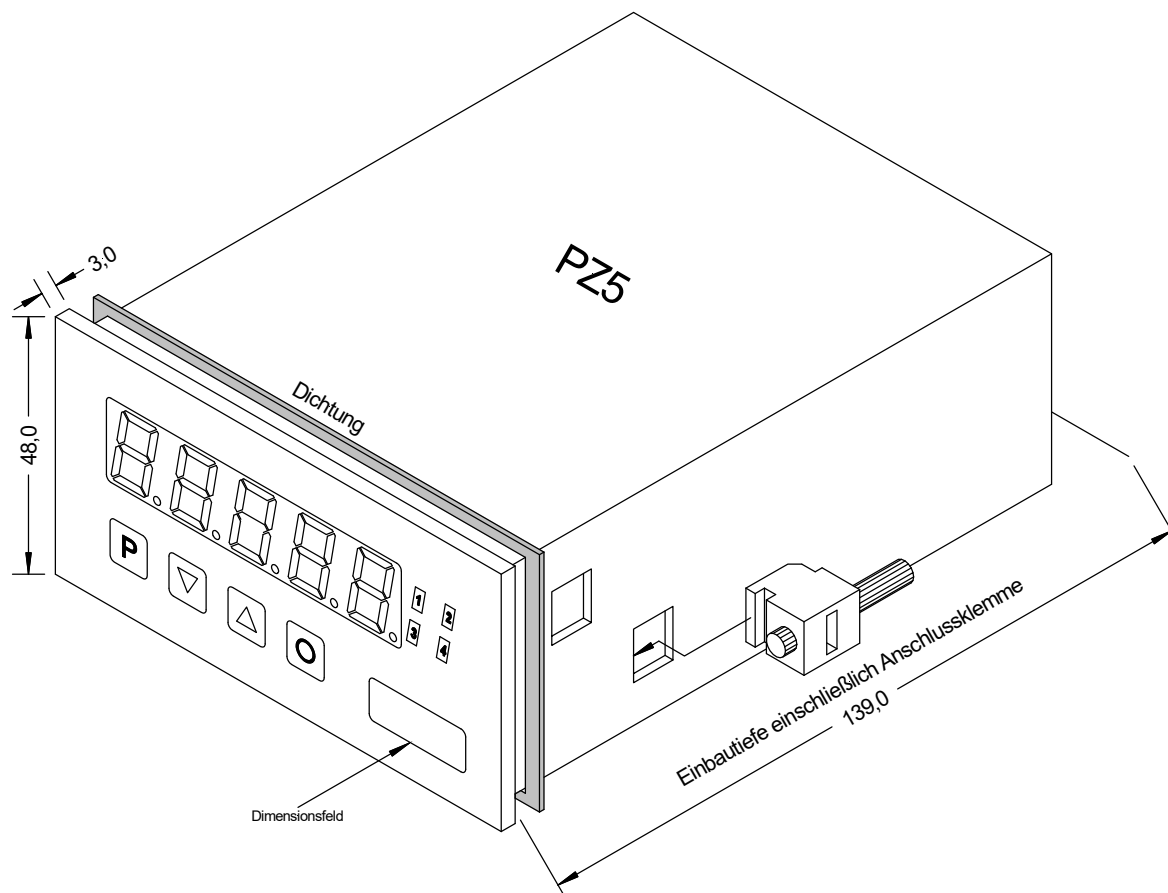

1. After removing the fixing elements, insert the device.
2. Check the seal to make sure it fits securely.
3. Click the fixing elements back into place and tighten the clamping screws by hand. Then use a screwdriver to tighten them another half a turn.

CAUTION! The torque should not exceed 0.1 Nm!

The dimension symbols can be exchanged before installation via a channel on the side!

5. Electrical connection

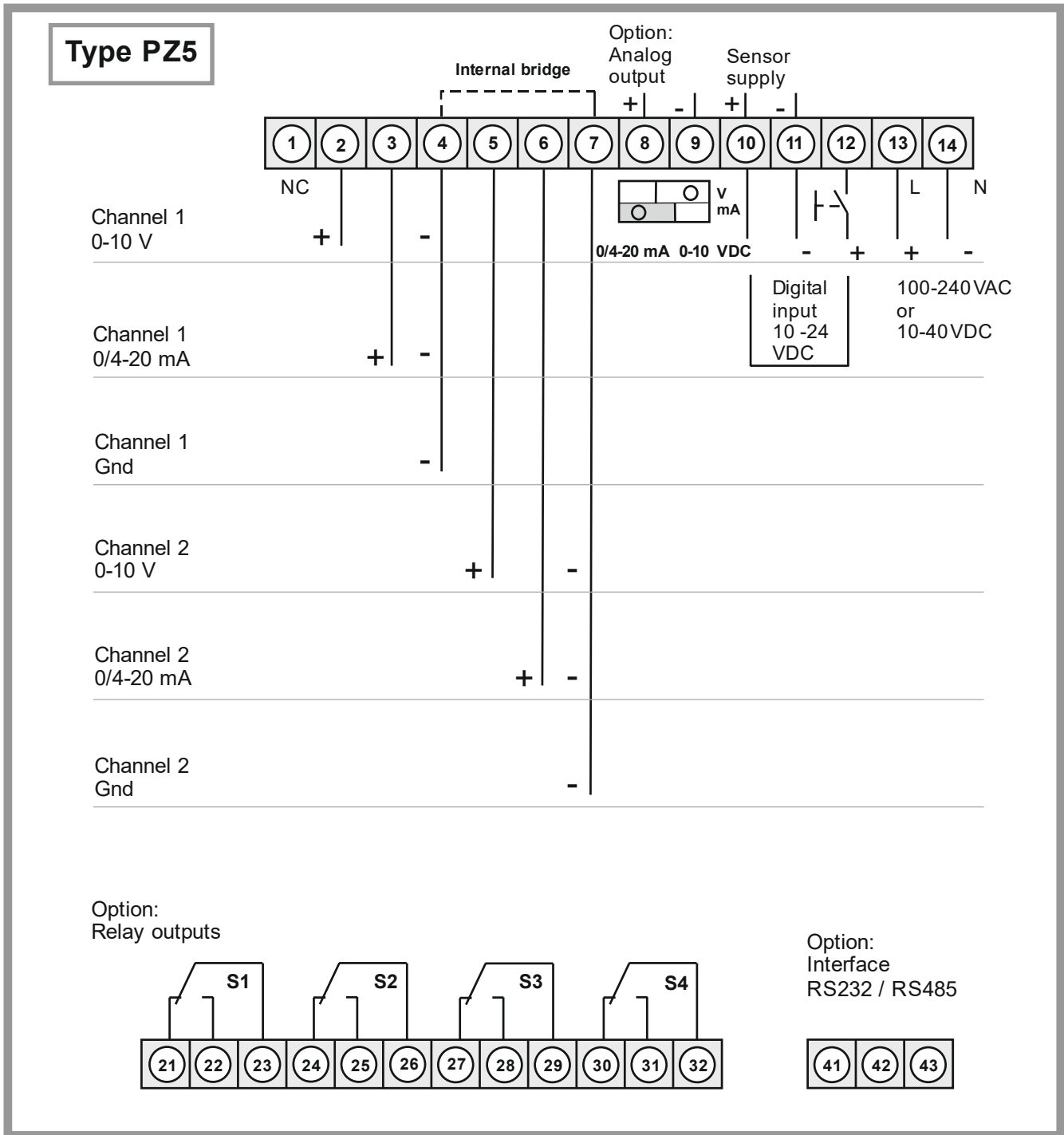

Interface connection

The lines for the **RS232** interface must be connected 1:1, TxD to TxD and RxD to RxD.

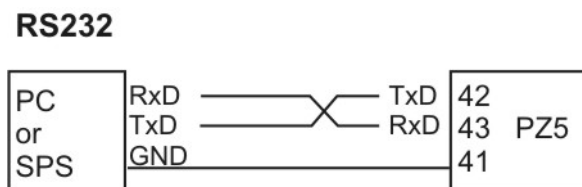

Connection pattern PC or SPS \Leftrightarrow **PZ5**

The interface **RS485** is connected via a screened data line with twisted wires (**Twisted-Pair**). A termination of the bus wire must be connected at the end of each bus segments. This is necessary to guarantee a save data transfer on the bus. Therefore a resistance (120 Ohm) is inserted between the wires Data B (+) and Data A (-).

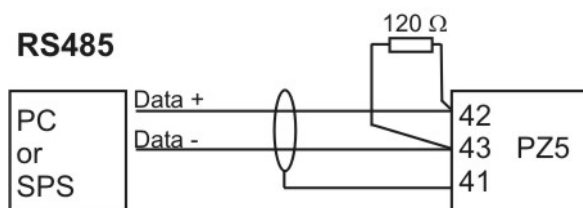

Caution!

The potential reference can lead to a compensating current (interface \Leftrightarrow measuring input) with a non-galvanic isolated interface and can thus affect the measuring signals.

Connection examples

This section gives a few examples of practical connections. Other connection options can be combined from the various examples:

Co-channel measurement with current signals, supply 100-240 VAC:

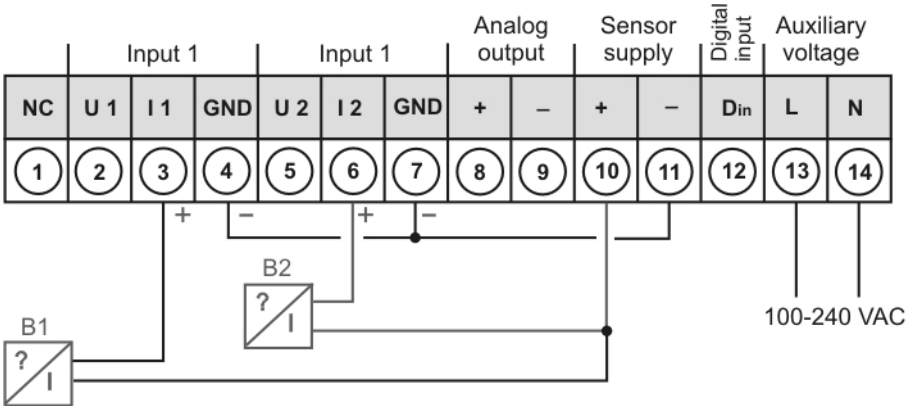

Co-channel measurement with voltage signals, supply 10-40 VDC:

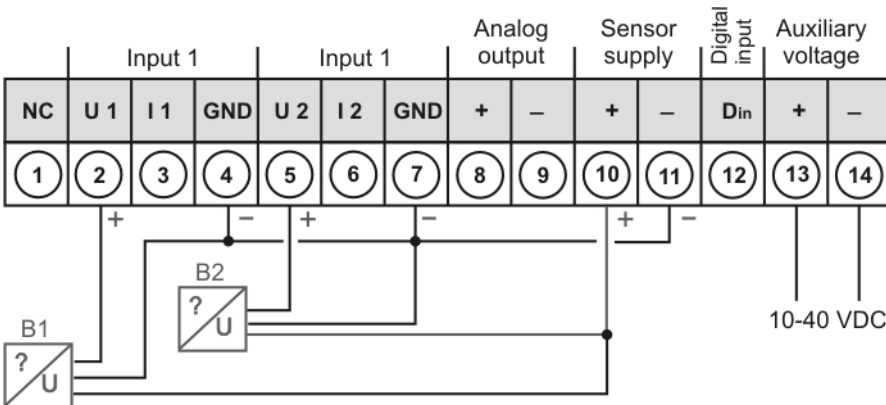

One-channel measurement with current signal in combination with digital input and sensor supply, voltage supply 230 VAC:

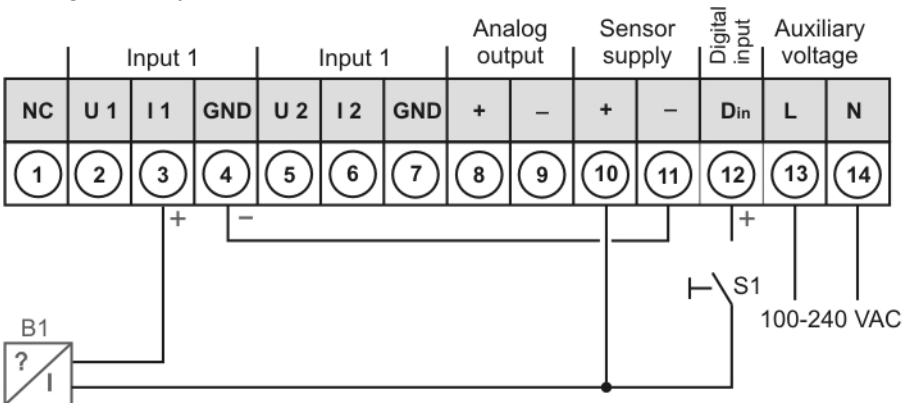

6. Operation and function description

6.1. Operation

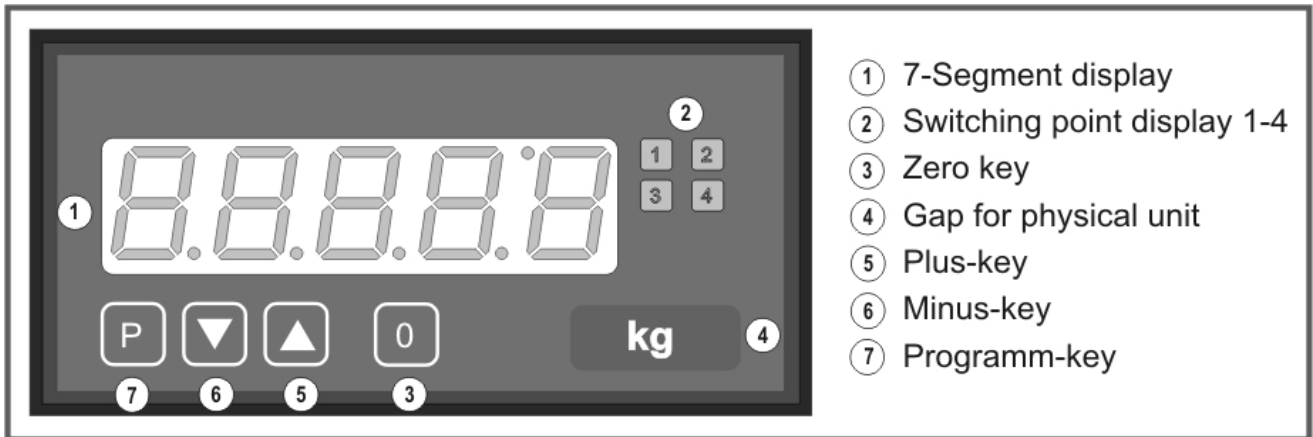

Display (1)	
7 segment display	5-digit, red
Digit height	14 mm
Display range	-9999...99999
Decimal points	none, 1, 2, 3, 4 (adjustable)
Switching point displays (2)	
Optical threshold message	4 LED, red
Keys (7), (5), (6), and (3)	
	Programming mode
	Increase of value range
	Decrease of value range
+	Address Next lower program number
+	Address Next higher program number
	Activation of TARA or HOLD, Reset for Min/Max permanent
Dimension gap (4) for physical unit	
Variable dimension strip	Dimension on demand e.g. kg, m ³ ...

Switching on

Before switching on, check all the electrical connections to make sure they are correct. On completion of the installation, the device can be switched on by applying the supply voltage.

Starting sequence

During the switching-on process, a segment test is performed for approx. 1 second, whereby all LED on the front (including setpoint LED) are triggered. After this, the type of software is indicated for approx. 1 second and then, also for 1 second, the software version. After the starting procedure, the unit changes to operation mode / display mode.

MIN/MAX memory

The measured minimum and maximum values are saved in a volatile memory in the unit and get lost when the unit is switched off.

Call up the contents of the memory by pushing (less than 1 second) the [▲] or [▼] key. The relevant value is indicated for approx. 7 seconds. By briefly pressing the same key again, one will return immediately to the display mode.

[▲] ⇒ Display of maximum value

[▼] ⇒ Display minimum value

Erase the value shown in the display by simultaneously operating the [▲] and [▼] keys. The erasure is acknowledged by horizontal bars. The content of the memory will be lost with switching-off of the device.

Display switch-over between two input channels

For the **PZ5** device it is possible to switch temporarily between the different channels via keypad. Push the [▼]- or [▲]-key for longer than 1 second, this leads to a switch-over to the next channel. The channels can be run through forwards with [▲]-key or backwards with [▼]-key.

Display:	Channel 1	Ch1
	Channel 2	Ch2
	Arithmetic	Ar
	Channel 1	Ch1 and so on...

Example:

Under program number (PN15≥3) the calculation (Ar) is parameterised as a permanent display. The input value for channel 1 shall be displayed:

Push the [▲]-key for at least one second. The **PZ5** device acknowledges the change to channel 1 by shortly displaying Ch1, thereupon stop pushing the key. The input value of channel 1 is shown for approx. 7 seconds in the display, then the display changes back to the parameterised display (arithmetic Ar). This operation is confirmed by showing „Ar“ in the display. To recall all channels, the [▲]- or [▼]-key needs to be detached in the meantime.

Overflow/Underflow of the arithmetic result

During the channel calculation the comma (PN18) is included in the calculation as decimal point. Each overflow or underflow of a channel leads in the calculation to a defined display. This defined setting ensures that the corresponding setpoints go into a defined state.

Formula	Channel 1	Channel 2	Result
$(\text{Channel 1} + \text{Channel 2}) * \text{Constant}$	Overflow	OK or overflow	Overflow
$(\text{Channel 1} + \text{Channel 2}) * \text{Constant}$	Underflow	OK or underflow	Underflow
$(\text{Channel 1} + \text{Channel 2}) * \text{Constant}$	OK or overflow	Overflow	Overflow
$(\text{Channel 1} + \text{Channel 2}) * \text{Constant}$	OK or underflow	Underflow	Underflow
$(\text{Channel 1} + \text{Channel 2}) * \text{Constant}$	Overflow	Underflow	Overflow
$(\text{Channel 1} - \text{Channel 2}) * \text{Constant}$	Overflow	OK or underflow	Overflow
$(\text{Channel 1} - \text{Channel 2}) * \text{Constant}$	Underflow	OK or overflow	Underflow
$(\text{Channel 1} - \text{Channel 2}) * \text{Constant}$	OK or overflow	Underflow	Overflow
$(\text{Channel 1} - \text{Channel 2}) * \text{Constant}$	OK or underflow	Overflow	Underflow
$(\text{Channel 1} - \text{Channel 2}) * \text{Constant}$	Underflow/Overflow	Underflow/Overflow	Overflow
$(\text{Channel 1} * \text{Channel 2}) * \text{Constant}$	Overflow	OK or overflow	Overflow
$(\text{Channel 1} * \text{Channel 2}) * \text{Constant}$	Underflow	OK or underflow	Underflow
$(\text{Channel 1} * \text{Channel 2}) * \text{Constant}$	OK or overflow	Overflow	Overflow
$(\text{Channel 1} * \text{Channel 2}) * \text{Constant}$	OK or underflow	Underflow	Underflow
$(\text{Channel 1} * \text{Channel 2}) * \text{Constant}$	Overflow	Underflow	Overflow
$(\text{Channel 1} / \text{Channel 2}) * \text{Constant}$	Overflow	Optional	Overflow
$(\text{Channel 1} / \text{Channel 2}) * \text{Constant}$	Underflow	Optional	Underflow
$(\text{Channel 1} / \text{Channel 2}) * \text{Constant}$	OK	Overflow	Underflow
$(\text{Channel 1} / \text{Channel 2}) * \text{Constant}$	OK	Underflow	Underflow
$(\text{Channel 1} * 100 / \text{Channel 2})$	Overflow	Optional	Overflow
$(\text{Channel 1} * 100 / \text{Channel 2})$	Underflow	Optional	Underflow
$(\text{Channel 1} * 100 / \text{Channel 2})$	OK	Overflow	Underflow
$(\text{Channel 1} * 100 / \text{Channel 2})$	OK	Underflow	Underflow

Overflow / Underflow	
Overflow	horizontal bars are displayed on the top of the display
Underflow	horizontal bars are displayed at the bottom of the display

6.2 Alarms / Relays

An active relay, or an activated switching point is indicated by a flashing of the relevant switching point LED, which you find directly next to the 7-segment display.

Functional principle of alarms / relays	
Alarm / Relay X	Channel 1, Channel 2, arithmetic calculation
Threshold	Switch-over threshold value
Hysterisis	Width of window between switching threshold
Working principle	Operating current / quiescent current
Switch-on delay	Time between reaching the threshold and the resultant switching on of the relay.
Swith-off delay	Time between reaching the threshold and the resultant switching off of the relay.

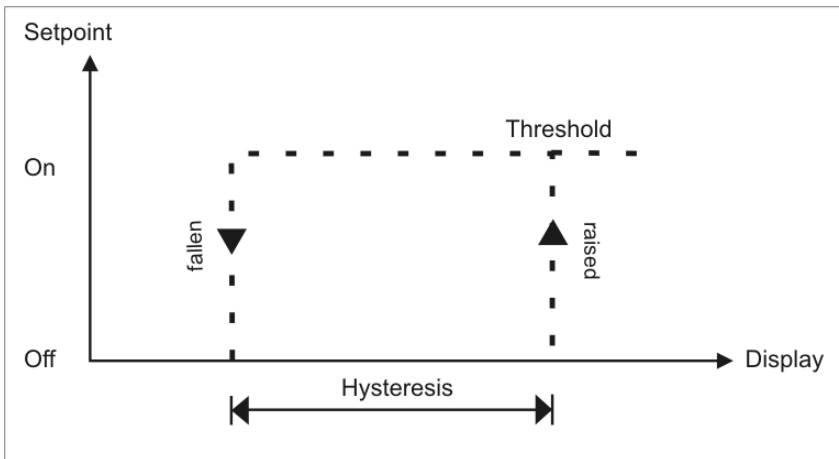
**Operating current**

Relays S1-S4 are off below the threshold and on on reaching the threshold.

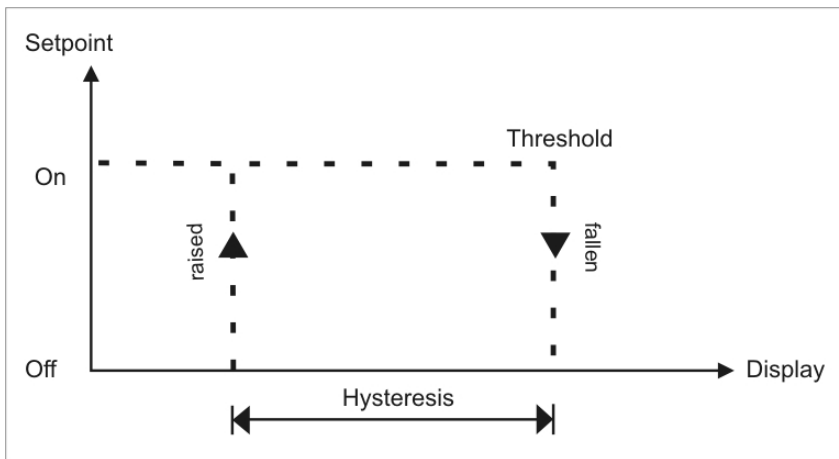
**Quiescent current**

Relays S1-S4 are on below the threshold and switched off on reaching the threshold.

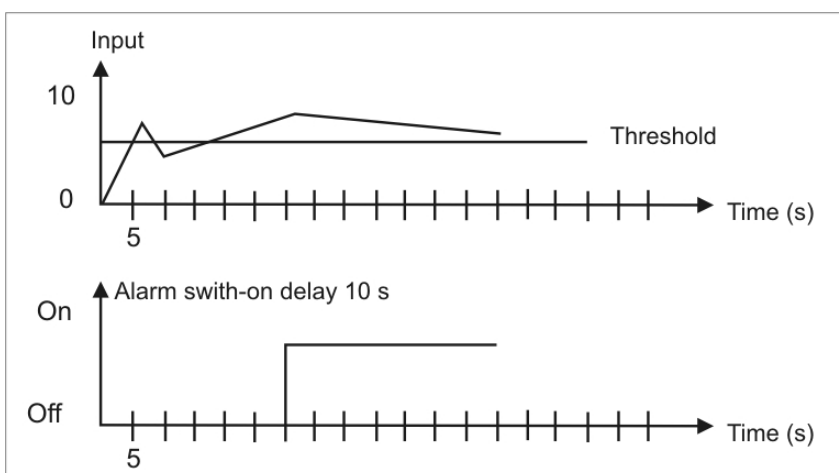
**Swith-on delay**

The relay S1-S4 is on 10 seconds after reaching the threshold; briefly exceeding the threshold does not lead to the relay being switched on. The switch-off delay functions in a similar manner, in other words it keeps the relay switched on until the parameterised time has elapsed.

Allocation of the alarms to a certain actuate value

As it is not always desired that alarms follow the operating mode, the outputs can be assigned to the minimal/maximal value or any other value. Therefore the adjustable value range is assigned to the according program number (PN60, PN70, PN80 and PN90).

Alarms 1-4	
Mode	Actuate value
0	none
1	Channel 1
2	Channel 2
3	Arithmetic function

Optical response, flashing display

If one or some thresholds are broken, the flashing of the alarm LED can amplify the optical response by assignment of the threshold PN59 to the 7 segment display.

Example:

The threshold for flashing of the display is set at alarm 2.

If alarm 1 is exceeded and alarm 2 is not, the alarm **LED 1** lights up permanently.

If alarm 2 exceeds the threshold, the 7-segment display will start to flash, alarm 1 will light up permanently and alarm LED 2 will flash.

The flashing enhances the optical response and the operator sees immediately that an important threshold has been exceeded with this unit.

6.3 Analogue output

The optional analogue output is used for the transduction of a measuring value, supported by a standard signal of 0...10 V or 0/4...20 mA. The analogue output is parameterised via the two program numbers PN20 final value (fullscale) and PN21 initial value (Offset). At the initial value, the value is set at which the analogue output transmits the minimal value (0 V or 0/4 mA), and at the final value, the value at which the output transmits its maximum (10 V or 20 mA).

By this means it is possible to rescale the input signal of a transducer or even to convert it into another standard signal. The analogue output can be set on channel 1, channel 2 or the arithmetic value via the actuate value PN22. The analogue output is updated within the cycle of the measuring time. At a high measuring rate, smaller cycle fluctuations of some milli-seconds are possible.

6.4. Digital input / Zero key

In combination with the digital input (via terminal) and/or the zero key at the front, functions like e.g. HOLD, TARA or a channel switch-over, can be actuated. The digital input is available in combination with the option sensor supply or via an external 24 VDC-signal. The zero key at the front of the device can be activated by keypress.

6.4.1 HOLD function

The HOLD function is a static or keyed signal and is activated via the digital input or the zero key. It always takes effect on the reference value that is allocated in the display. With activated HOLD the lastly given measuring value remains and is by deactivation permanently overwritten by the measuring value recording. With this function a test state can be recorded beyond a specific period, so that this device can be used for control in run production, too.

Advice: HOLD value gets lost with restart!

6.4.2 TARA function

The TARA-Function can be activated by zero key or digital input and needs to last for at least 3 seconds. Thereby the instantaneous value of the channels is set on zero and the difference to the actual value in PN4/PN9 (Offset displacement) is stored. This function is only done once, after actuation of the desired trigger and has to be taken back before a new alignment. The display reports this action by showing five little zeros in the display **00000**.

6.4.3 Configurable channel switch-over

The two input channels can be addressed via zero key, externally via the digital input or time-controlled. This enables the user to see different measuring values in display change mode under PN11.

6.5. Interface RS232 / RS485

All **PZ5** devices can optionally be programmed or configured via an interface. Devices of the basic type do not have an interface.

Operating mode

The interface can be operated in various modes that can be parameterised via the PN34 (Interface behaviour).

PN34=0

Standard mode in which the unit only replies if called on to do so. This mode is used only for configuration. Furthermore the current measuring value can be recalled via command **"A ↵"**.

PN34=1

Transmission mode in which the measurements are transmitted via the serial interface cyclically with the set measuring time.

The transmission mode is interrupted on receipt of **"> ↵"** and the unit changes to standard mode. To change back to transmission mode, the display must be restarted, either by entering the command **"S ↵"** or by switching the device off and on.

With the transmission mode, the display value is transmitted via the interface in ASCII format. Minus signs and decimal points are also transmitted so that the output can be displayed directly on a terminal or processed by a SPS. Zeros at the front are suppressed during transmission. With an over or underflow, the display transmits horizontal bars (hyphens) **"- - - - ↵"**.

Examples: "0.00 ↵" ; "-9.99 ↵" ; "999.99 ↵" ; "-123.45" ; "- - - - ↵"

With the aid of this simple protocol structure, the display data can be transferred very easily to a PC etc. and further processed there. In the simplest case, a terminal program from the operating system is sufficient to store the received data in a file.

Configuration of the device via interface

For configuration the set-up tool **PM-Tool** can be used. As the communication is a straight point-to-point connection. The baud rate is set to 9600 baud, with 8 databits, without parity and one stopbit. Configuration is performed by transmitting **ASCII symbols**.

7. Programming

Functional diagram of programming via key pad

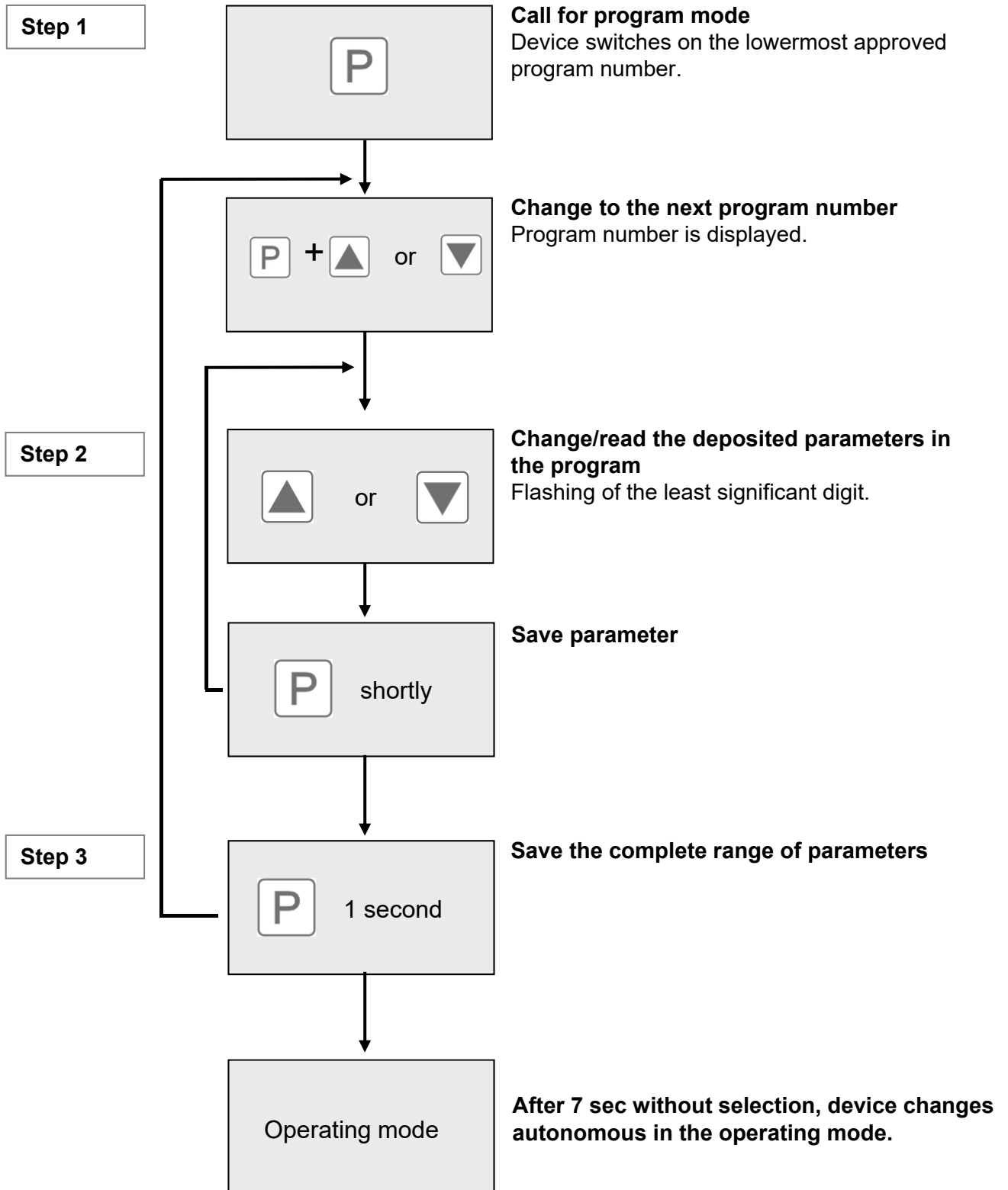

Description of the program numbers

In the display, the program numbers (PN) are shown, right-justified, as a 3-digit number with a **[P]** in front of them:



Display of e.g. program number 0

Programming procedure

The entire programming of the **PZ5** is done by the steps described below.

Change to programming mode

Push the **[P]**-key to change into programming mode. The unit goes to the lowest available program number. If the programming lock is activated, the key must be pushed for at least 1 second.



Change between program numbers

To change between individual program numbers, hold the **[P]**-key down and push the **[▲]**-key for changing to a higher program number or the **[▼]**-key for changing to a lower number. By keeping the keys pushed, e.g. **[P] + [▲]**, the display will begin, after approx. 1 second, to automatically run through the program numbers.

Change to the parameter

Once the program number appears in the display, push **[▼]** or **[▲]** key to get to the set of parameters for this program number. The currently stored parameters are displayed.

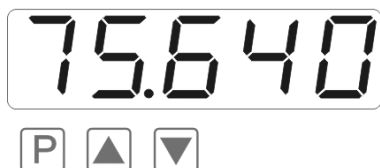

In this case, it is 75,640

Changing a parameter

After changing to the parameter, the lowest digit of the respective parameter flashes on the display. The value can be changed with the [▲]- or [▼]-key. To move to the next digit, the [P]-key must be briefly pushed. Once the highest digit has been set and confirmed with [P], the lowest digit will begin to flash again.



Example:

The 0 is flashing. This is the lowest digit and the device asks if a change is desired. Let us assume the figure has to be changed from 75,640 to 75,000.

Briefly push the [P]-key to move to the next digit. The 4 begins to flash. Change the figure by pushing [▲] or [▼] to change the digit from 4 to 0. Briefly push the [P]-key to move on to the next digit. The 6 begins to flash. Change the digit by pushing [▲] or [▼] to move the 6 to a 0. Briefly push the [P] key to move to the next digit. The 5 and 7 do not need to be changed.

Saving of parameters

All parameters must be acknowledged by the user by pushing the [P]-key for one second. The changed parameters are then taken over as the current operating parameters and saved in the EEPROM. This is confirmed by horizontal bars lighting up in the display.

All the newly entered data are confirmed by the unit. If no confirmation is received, the relevant parameters have not been saved, e.g. confirmation of parameters:



Changing from programming to operating mode

If no key is pushed in the programming mode for about 7 seconds, the unit will return automatically to operating mode. Before „SAVE“ will be displayed until the next measuring value is displayed.

Two measuring inputs with arithmetic function

The **PZ5** is provided with two standard inputs, which can be allocated via different types of arithmetic functions. The inputs need to be configured, so the device works according to the signal that was generated by the sensor. The adjustment of the parameter that form the basis is done under PN0 and PN5.

Setting / Calibration of the measuring input

All devices are calibrated in the factory, whereby zero point and final value have been saved for the various measuring ranges. Via terminal connections and the choice of the measuring input under PN0, different types of input signals can be worked up.

Factory calibration current / voltage under PN0/PN5=1...3

For these parameters, scaled display values can be allocated to defined input values. For the adjusted measuring range, the final value and the zero point need to be parameterised. For parameterisation, no sensor signal has to be applied because stored values are used. To display a sensor signal of 4...20 mA, for example PN0/PN5=3 has to be parameterised.

Sensor calibration PN0/PN5=4/6

During sensor calibration, the device is calibrated directly at the measuring section via the sensor signal or a calibrator. Therefore the measuring signal of the supporting point needs to be connected to the input of the device. Under PN1 (final value) and PN2 (zero point) the related display value (*SCALE*) and the related sensor signal (*INPUT*) needs to be stored. The sensor signal is measured by the factory parameter and displayed as current or voltage. A measurement needs to be started by shortly pushing the **[P]**-key. By this process with 2 supporting points the device is aligned at the measuring section. For further adjustments to the characteristic line of the sensors, a linearisation can be activated.

Linearisation PN100/PN140

The **PZ5** offers the possibility to linearize, with up to 30 additional supporting points, non-linear sensors for the display of the measuring values and their subsequent processing (analog output).

The number of the desired supporting points is determined under PN100/PN140. Be aware of choosing the right one, as it can lead to a malfunction of the device in case of no adjustment.

Approach to sensor calibration for e.g. channel 1

To program e.g. 5 supporting points, 5 needs to be entered under PN100. Subsequently, for each of the calibration points, the measured variable must be applied to the unit and the respective display value needs to be parameterised under program numbers PN101–PN105. The sensor signal needs to be parameterised strictly increasing. A distance from at least +1 digit to the previous display value should be kept. If not, a rejection in the form of not receiving a memory report (- - - -).

Our example shows the linearisation of a pressure transducer for 0-100 mbar with an output of 0-20 mA and a nonlinear range between 0-75 mbar. The display value is calculated from the known characteristic line of the transducer or determined empirically.

This means, at a pressure of 15 mbar the transducer supplies 3.3 mA instead of the optimum value of 3.0 mA. As 20 mA corresponds with a presentation of 100.0, 3.3 mA corresponds with 16.5 before correction. To make this correction, enter 15.0 under supporting point PN101.

Supporting point (PN)	Pressure (mbar)	Output transducer (mA)	Display before correction (IN)	Desired display (OUT)
2	0	0.5	2.5	0.0
101	15	3.3	16.5	15.0
102	30	6.2	31.0	30.0
103	40	9.2	46.0	40.0
104	60	11.4	57.0	60.0
105	75	14.7	73.5	75.0
1	100	20.0	100.0	100.0

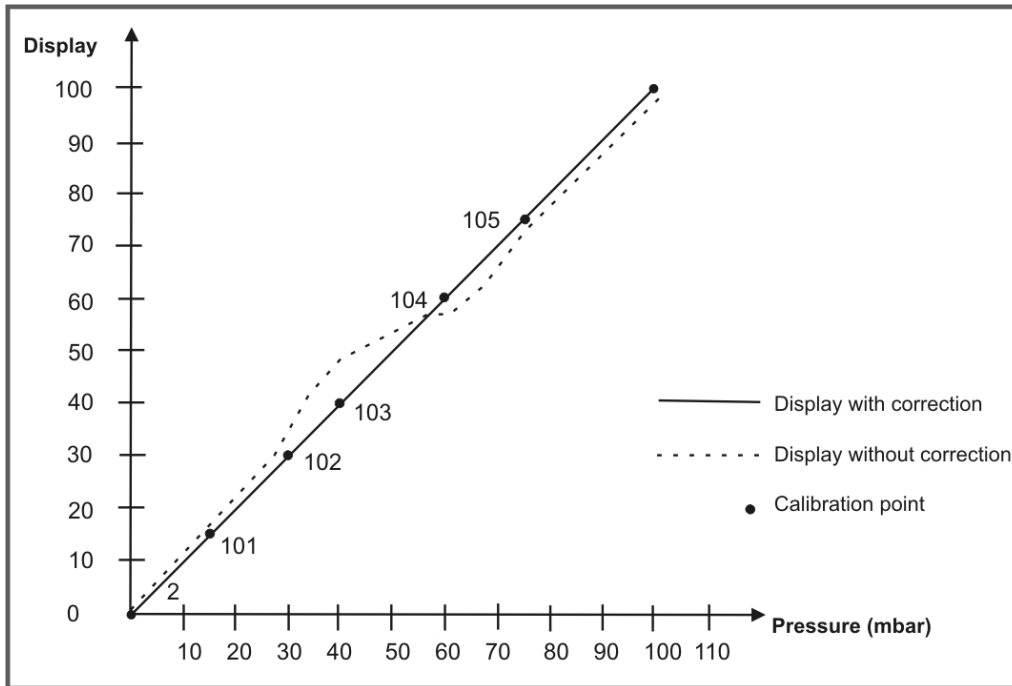

Approach to factory calibration PN0/PN5 > 0

During adjusted factory calibration, a linearisation can be preset, without applying to the sensor signal. Here the desired number of channel supporting points needs to be entered under PN100/PN140, in order to allocate display values to a defined measuring signal. Starting on supporting point PN101 the display value (Scale) and subsequent the corresponding measuring signal (Input) need to be programmed. Both actions are stored by pushing the **[P]**-key (for approx. 1 second).

Input channels and Offset

The **PZ5** device has two input channels, where standard signals (optionally 0...10 V, 0...20 mA or 4...20 mA) can be connected. Different signals can be collected for input signals, e.g. channel 1 collects voltage and channel 2 collects current. For each channel an arbitrarily measuring range can be set.

The offset displacement can be adjusted for each channel with PN4 and PN9. Thus an irregularity of the accuracy or drifts of sensors can be balanced.

Two channel measurement with calculation

The measurement happens in an alternating process, during this process it will be switched between the set measuring time and the two input channels. The time of the particular individual measurement depends on the parametrised measuring time.

Afterwards the two ascertained values will be allocated in accordance to the in PN15 selected function, and the result will be displayed. The arithmetic functions of the device are based on a floating-point arithmetic and include the parameterised comma in the calculation.

Single channel measurement

A single channel measurement is done, if one of the measuring channels was selected as display value via the PN15. In this case only the selected channel will be measured and displayed. That way, the measuring time PN14 can be set on a smaller value (100 ms). If 200 ms was adjusted by a two channel measurement, then this value will not be changed.

If the **PZ5** is parameterised on a one channel measurement, then the access to the program numbers of the deactivated channels is not possible.

The channel, on which no measurement is done and the arithmetic result receive the measuring/display value „0“ (Zero). Thereby supporting points or the analog output, which are parameterised on these channels, are shifted to a defined state.

Arithmetic functions

With the **PZ5** the measured values can be allocated with each other by different mathematical functions.

For the following examples, the values of the channels and the constants are defined as follows:

Channel 1	=	100,0
Channel 2	=	40,00
Constant	=	20
Display	=	xxxx,x

Addition (Channel 1 + Channel 2) * Constant

With this function, the two scale signals are added and subsequently multiplied by a constant.

Example: $(100,0 + 40,00) * 20 = 2800,0$

This function can be used to display inflow/outflow volumes, weighing technology, etc .

Subtraction (Channel 1 – Channel 2) * Constant

With this function, the difference from channel 2 to channel 1 is multiplied by a constant.

Example: $(100,0 - 40,00) * 20 = 800,0$

This function can be used to display differences etc.

Multiplication (Channel 1 * Channel 2) * Constant

With this function, the two scaled signals are multiplied with each other and then multiplied by a constant.

Example: $(100,0 * 40,00) * 20 = 80000,0$

This function can be used to display power, energy etc.

Ratio (Channel 1 / Channel 2) * Constant

With this function, the ratio is formed between the scaled signals of channel 1 and channel 2 and then multiplied by a constant.

Example: $(100,0 / 40,00) * 20 = 50,0$

This function can be used to display mixing ratios etc.

Percent (Channel 1 * 100 / Channel 2)

With this function, the scaled signal from channel 1 is multiplied by 100 and then divided by the scaled signal from channel 2.

Example: $(100,0 * 100) / 40,00 = 250,0$

This function can be used to display a percentage ratio.

8. Program number description

The **PZ5** device has a default configuration ex factory, where sensor signals are changed into a display value of 0...10000. At reset on default values should be done for devices, where their preconfiguration is not known (see *chapter 9*). Otherwise different adjustments can cause an unwished behaviour of the device. These devices are equipped with a digital input, by which functions like e.g. HOLD, TARA, MIN/MAX can be actuated.

Measuring input PN0/PN5

For basic configuration of the device, parametrise the suitable measuring input under PN0/PN5. Possible input types are listed in the program number table (*Chapter 8.1*).

To assign characteristic lines into another device, use the settings 4/5 or 6 under PN0/PN5. Under this parameter supporting points are deposited as standardized values (Current, voltage) and can be assigned by an optional interface into further devices.

Scaling of PN1/PN6 and PN2/PN7

PN1/PN6 and PN2/PN7 are used for the scaling of the device, with these two parameters, final value (PN1/PN6) and zero point (PN2/PN7) are parameterised. For each supporting point there is a *SCALE*-value and an *INPUT*-value. The *SCALE*-value indicates the desired display value. By use of the *INPUT*-value, the related measuring signal is set. At factory calibration the desired current or voltage value is preset. If sensor calibration is desired, a measurement is actuated by shortly pushing the **[P]**-key. Before, the stored current or voltage value is displayed. All inputs need to be confirmed by pushing the **[P]**-key for approx. 1 second; the device confirms this by showing 5 horizontal bars.

Position after decimal point PN3/PN8

By changing this parameter, the position of the comma in the display is changed.

Offset translation / Zero point translation PN4/PN9

With this parameter it is possible to do a parallel translation of the parameterised characteristic line. This can be necessary if e.g. a pressure sensor seasons by and by and thus causes a zero point translation. With corresponding parameterisation, the sensor can be adjusted on the zero point again. During offset translation, the original characteristic line can be programmed by the user with help of PN1, PN2 or PN101...130, or it can be the characteristic line of a temperature sensor. The value parameterised under PN4 is added to the original display value. If e.g. a temperature sensor shows 0°C instead of 3°C, these irregularities can be compensated by changing the value under PN4 from 0 to -3.

This parameter can be changed directly by taring, if it was actuated by the zero-key or the digital input.

Default display channel PN10

The **PZ5** can be parameterised and displayed on any display channel, independent of the calculation.

If the arithmetic function $PN15=0$ is deactivated, the channel value is set on zero.

Configurable channel switch-over PN11

This program number enables the user to see all measuring values of the channel and the arithmetic function during standard operation.

Therefore all different types of operation like e.g. a static, keyed or automatic display change are supported by the device.

Before each change of the channel, the device shows the name of the channel in the display. For channel 1 it displays „**Ch1**“ and for channel 2 it displays „**Ch2**“. For the arithmetic function it displays „**Ar**“, if it was activated by $PN15 > 0$.

The static and keyed channel switch-over can be triggered via the digital input or the fourth key. The selection is done via program numbers PN53 and PN54.

At the static channel switch-over it is changed as long on the via PN11 selected channel ($PN11=1...3$), as the related digital input or the zero-key is deactivated again.

At the keyed channel switch-over it is changed in the order “Ch1”, “Ch2” and optional “Ar” at each actuation of the defined activator.

During the time-controlled automatic channel switch-over the display switches from one channel to the next following one during the preset time cycle (“Ch1”, Ch2” optional “Ar”). If the arithmetic function is deactivated (PN15=0), the display only changes between the two display values of channel 1 and channel 2.

Even at activated display change MIN/MAX-values of the currently active display channel can be recalled via [▲] & [▼]-keys. The channel switch-over is delayed by the MIN/MAX-display time.

Display time PN13

Under display time the time is set, that shall pass between the update of the display. The longer the time between two display cycles, the optically calmer seems the display, whereas a display time of 1 second is found very pleasant.

Measuring time PN14

The device always executes a two channel measurement. For a measuring interval (adjustable via PN14) it is switched to and for severable times between the input channels and by the individual measurements per channel, a simple arithmetic average determination is used. The conversion time of the integrated AD-converter is aligned dynamically to the measuring time.

Set measuring time/s	< 0.25	< 0.5	< 0.8	> 0.8
Conversion time/ms	approx. 30	approx. 60	approx. 120	approx. 180

The AD-converter is equipped with a digital filter function, which suppresses very effectively a possible mains hum (50 Hz). To use this function, a measuring time from more than 0.5 seconds should be selected.

Arithmetic Function PN15

Under this function the calculation type of the channels is set. The different functions can be seen in the program number table *Chapter 8.1*.

The arithmetic function is completely calculated in floating-point-arithmetic. Thereto the scaled measuring values of both input channels are calculated and processed in floating-point-arithmetic, too. According to this the resolution of the single channels can be clearly higher than the display value. For the calculation a bit mantissa and a 8 bit exponent are used. For this reason the adjusted comma (PN3, PN8, PN17, PN18) need to be included at the calculation.

CAUTION!

The outputs work only with the display value and reach especially at the optional analog output only its resolution

Analog output PN20, PN21, PN22 and PN23

The parameter of the optional analog output apply to the scale of the device and are cyclical updated with the measuring time. Via PN22=0 the analog output can be deactivated, whereas it remains on its initial value after a restart of the device.

The Analog output can be related to all other possible values that are collected in the device. For further information please see *Chapter 7* or the program number table in *Chapter 8.1*.

Initial value and final value are always displayed without comma. This is always based in the depiction of the measuring value in the display, this means at a depiction of e.g. 6.400 the final value can be parameterised by 6400 to this display value.

PN23 determines the output signal, whether 0-20 mA, 4-20 mA or 0-10 VDC are possible.

Interface behaviour PN34

The current display value can be sent via the optional interface. In standard operation PN34=0 the display stays passive and expects data from the Bus. This operation is suitable for the configuration of the device. At slowly processes the current measuring value can be recalled actively via command. During sending mode PN34=1, the current measuring value is sent actively by the device in the cycle of the measuring time. Further information can be found in *Chapter 7 / Operation mode*.

Security settings / User level PN50 to PN52

The access to the program numbers is controlled by the security settings. The user has only access to settings that were allowed by the plant operator, like e.g. the adjustment of the alarm thresholds. The smaller the numerical value of the under PN52 preset user level, the larger is the grade of the saving of the device parameter from user interventions.

User level PN52=		0	1	2	3	4	5	6	7	8
Access to:	PN									
Display brightness	19	X	X	X	X	X	X	X	X	X
Programming lock	50	X	X	X	X	X	X	X	X	X
Serial number	200	X	X	X	X	X	X	X	X	X
Alarm threshold value	61, 71, 81, 91	X	X	X	X	X	X	X	X	
Alarm parameter	59...95	X	X	X	X	X	X	X		
Interface parameter (Option)	32...34	X	X	X	X	X				
Analog output parameter (Option)	20...22	X	X	X	X	X				
Measuring input parameter	0...18	X	X	X						
Linearisation parameter for the meas. input	100...170	X	X	X						
Activation code	51	X								
User level	52									

The user level 1,3 and 5 are reserved. With rising userlevel, the number of for the user unlocked parameters decreases, according to the above shown table.

The user level adjusted under PN52 is activated, as long as the programming lock **PN50** differs with the activation code **PN51** on a value basis. For dispatch of the **PZ5**, both parameter are set to the values 0000, by what the programming lock is deactivated.

To activate the adjusted user level, a 4-digit number needs to be entered as activation code under PN51. It needs to be confirmed by pushing the **[P]** key for approx. 1 second.

During the change into program mode the device switches to the first program number that is available. If user level PN52=3 is parameterised, e.g. the access to the program numbers of the alarms is approved, a change of the measuring input PN0 is not possible for this setting.

To receive the access to all program numbers (PN52=0), the programming lock under PN50 and the under PN51 stored 4-digit activation code need to be entered again and to be acknowledged by pushing the **[P]**-key for approx. 1 second. After this the access to all program numbers is free.

Caution! If the locking code got lost, the device can be reset to the default value 0000 by the manufacturer, without any data loss.

Digital input and/or zero key PN53, PN54

The digital input and the zero key can freely be related to additional functions (Change of display, HOLD, TARA). Only by combination of activation and one additional function with activation of the related activator, the extended functionality can be used.

Taring PN55

During taring the instantaneous value of the selected channels is set on zero and the difference to the actual value is stored in program number PN4 respectively PN9. The taring function can be actuated via the digital input or the zero key and needs to stay activated for at least 3 seconds. The device reports the taring process by showing *00000* in the display. The offset displacement is only related to the resolution of the display value! The taring can be undone by programming program number PN4 or PN9 to the value zero.

HOLD-Function PN56

Here the current display value is recorded. An update of the device with a new measuring value is not happening any more. To display this state, the display flashes with the kept display value.

This function can be activated keyed or static. During keyed mode, it is kept until the next activation, this is done by shortly and uniquely activating the actuator, which can be the digital input or the 4th key. During static HOLD the actuator needs to stay active for the whole length of time of the HOLD-function. The HOLD-function and the display flashing to threshold values (PN12) use both the flashing of the display value. Both differ in the flashing frequency, which is clearly higher for the display flashing on threshold values. For a better differentiation and to avoid a mix-up, one should surrender one of both function as a rule.

Alarms / Relay PN59 to PN95

The behaviour of the alarms can be influenced by different program numbers. The general information refer to the scaled measuring value and are updated by the set measuring time. If the optional relays are included in the display, then they are connected parallelly to the alarms. More details about the different parameter are described in *Chapter 6.2. Alarms/Relays*.

Linearisation PN100 to PN130 and PN140 to PN170

By linearisation the user has the possibility to linearise a nonlinear sensor signal. A detailed description can be found in *Chapter 8 / Linearisation PN100 ≥ 0*.

Serial number PN200

Here the 5-digit serial number can be recalled; it describes an allocation to production process and production flow.

8.1 Program number table

The following program number table contains all program numbers (PN) including function, range of value, default values and user level.

PN	Function	Range of value	Default	User level
Channel 1				
0	Measuring input	0 = Sensor calibration 1 = 0...10 V (Factory calibration) 2 = 0...20 mA (Factory calibration) 3 = 4...20 mA (Factory calibration) 4 = 0...10 V (Sensor calibration) 5 = 0...20 mA (Sensor calibration) 6 = 4...20 mA (Sensorkalibration)	0	2

PN	Function	Range of value	Default	User level
1	Final value / Fullscale	-9999...99999	10000	2
2	Initial value / Offset	-9999...99999	0	2
3	Comma setting	00000...0,0000	none	2
4	Offset displacement	-9999...99999	0	2
Channel 2				
5	Measuring input	0 = Sensor calibration 1 = 0...10 V (Factory calibration) 2 = 0...20 mA (Factory calibration) 3 = 4...20 mA (Factory calibration) 4 = 0...10 V (Sensor calibration) 5 = 0...20 mA (Sensor calibration) 6 = 4...20 mA (Sensor calibration)	0	2
6	Final value / Fullscale	-9999...99999	10000	2
7	Initial value / Offset	-9999...99999	0	2
8	Comma setting	00000...0,0000	none	2
9	Offset displacement	-9999...99999	0	2
General settings				
10	Default display channel	1 = Channel 1 2 = Channel 2 3 = Arithmetic function	3	2
11	Channel switch-over via digital input, zero-key or automatically	0 = none ([▲]-/[▼]-key) 1 = static change of display to channel 1 2 = static change of display to channel 2 3 = static change of display to arithmetic function 4 = keyed change of display 5 = 5 s – change-over cycle 6 = 10 s – change-over cycle 7 = 20 s – change-over cycle	0	2
13	Display time	0.1...10.0 s	1.0	2
14	Measuring time	0.04 ...10.00 s two channels 0.02 ...10.00 s one channel	0.20	2
15	Arithmetic function, only with 2 input channels K1 = Channel 1 K2 = Channel 2 Konst = Constant PN16/PN17	1 = $K_1 * Konst$ 2 = $K_2 * Konst$ 3 = $(K_1 + K_2) * Konst$ 4 = $(K_1 - K_2) * Konst$ 5 = $(K_1 * K_2) * Konst$ 6 = $(K_1 / K_2) * Konst$ 7 = $(K_1 * 100 / K_2)$	3	2
16	Constant	-9999...99999	1	2
17	Decimal places of the constant	0...4	0	2

PN	Function	Range of value	Default	User level
18	Decimal places of the calculation	00000...0,0000	0	2
19	Display brightness	0...9 (0= bright, 9 = dark)	3	8
Analog output				
20	Final value for analog output (Option)	-9999...99999	10000	2
21	Offset value for analog output (Option)	-9999...99999	0	2
22	Reference value for analog output	0 = none 1 = Ch1 2 = Ch2 3 = arithmetic function	3	2
23	Signal selection	0 = 0-10 VDc 1 = 0-20 mA 2 = 4-20 mA	2	4
Interface				
34	Switching of the interface behaviour	0 = Standard operation 1 = Sending operation	0	4
Programming lock				
50	Programming lock	0000...9999	0000	8
51	Access code	0000...9999	0000	0
52	User level	0...8	8	0
Function of the special inputs				
53	Function of the digital input	0 = no function 1 = change of display 2 = Hold function 3 = Tara	0	2
54	Function of the 4th key	0 = no function 1 = change of display 2 = Hold function 3 = Tara	0	2
55	TARA-Function	0 = no Tara-function 1 = Tara-function on channel 1 2 = Tara-function on channel 2 3 = Tara-function on Ch.1&Ch.2	0	2
56	HOLD-Function	0 = no Hold 1 = keyed Hold 2 = static Hold	0	2
Threshold behaviour of the LED-display				
59	Display flashing (approx. 0.5 seconds) No flashing Flashing at swicthing point 1 Flashing at swicthing point 2 Flashing at swicthing point 3 Flashing at swicthing point 4 Flashing at swicthing point 1 & 2 Flashing at swicthing point 3 & 4 Flashing at swicthing point 1, 2, 3 & 4	0 = not flashing 1 = flashing at 1 2 = flashing at 2 3 = flashing at 3 4 = flashing at 4 5 = flashing at 1 & 2 6 = flashing at 3 & 4 7 = flashing at 1, 2, 3 & 4	0	6

PN	Function	Range of value	Default	User level
Switching point 1				
60	Reference value for switching point 1	0 = none 1 = channel 1 2 = channel 2 3 = arithmetic function	1	6
61	Threshold	-9999...99999	1000	6
62	Hysterisis	1...99999	1	6
63	Type of operation: Quiescent current / Operating current	0 = Quiescent current 1 = Operating current	1	6
64	Switching delay	0.0...10.0 seconds	0.0	6
65	Type of delay	0 = none 1 = Switching-on delay 2 = Switching-off delay 3 = Switching-on/-off delay	1	6
Switching point 2				
70	Reference value for switching point 2	0 = none 1 = channel 1 2 = channel 2 3 = arithmetic function	1	6
71	Threshold	-9999...99999	1000	6
72	Hyterisis	1...99999	1	6
73	Type of operation: Quiescent current / Operating current	0 = Quiescent current 1 = Operating current	1	6
74	Switching delay	0.0...10.0 seconds	0.0	6
75	Type of delay	0 = none 1 = Switching-on delay 2 = Switching-off delay 3 = Switching-on/-off delay	1	6
Switching point 3				
80	Reference value for switching point 3	0 = none 1 = channel 1 2 = channel 2 3 = arithmetic function	1	6
81	Threshold	-9999...99999	1000	6
82	Hyterisis	1...99999	1	6
83	Type of operation: Quiescent current / Operating current	0 = Quiescent current 1 = Operating current	1	6
84	Switching delay	0.0...10.0 seconds	0.0	6
85	Type of delay	0 = none 1 = Switching-on delay 2 = Switching-off delay 3 = Switching-on/-off delay	1	6

PN	Function	Range of value	Default	User level
Switching point 4				
90	Reference value for switching point 4	0 = none 1 = channel 1 2 = channel 2 3 = arithmetic function	1	6
91	Threshold	-9999...99999	1000	6
92	Hysteresis	1...99999	1	6
93	Type of operation: Quiescent current / Operating current	0 = Quiescent current 1 = Operating current	1	6
94	Switching delay	0.0...10.0 seconds	0.0	6
95	Type of delay	0 = none 1 = Switching-on delay 2 = Switching-off delay 3 = Switching-on/-off delay	1	6
Linearisation				
100	Number of additional supporting points channel 1	0...30	0	2
101...130	Supporting points 1...30 channel 1	-9999 ... 99999		2
140	Number of additional supporting channel 2	0...30	0	2
141...170	Supporting points 1...30 channel 2	-9999 ... 99999		2
Information				
200	Serial number	0...99999	xxxxx	8

9. Reset to default values

To return the unit to a defined basic state, a reset can be carried out to the default values.

The following procedure should be used:

- Switch off the power supply
- Press **[P]**-button
- Switch on the power supply and press **[P]** for approx. further 2 seconds.

With reset, the default values of the program table are loaded and used for subsequent operation. This puts the unit back to the state in which it was supplied.

Caution!

- This is only possible when the programming lock PN50 allows access to all PNs or *HELP* is shown in the display.
- All application-related data are lost.

10. Error elimination

The following list gives the recommended procedure for dealing with faults and locating their possible cause.

	Error description	Measures
1.	The unit permanently indicates overflow.	<ul style="list-style-type: none"> • The input has a very high measurement, check the measuring circuit. • With a selected input with a low voltage signal, it is only connected on one side or the input is open. • Not all of the activated supporting points are parameterised. Check if the relevant parameter PN1/PN5, PN2/PN6, PN100/PN140... PN130/PN170 are adjusted correctly • The arithmetic result produces an overflow, see <i>Overflow / Underflow, page 14</i>.
2.	The unit permanently shows underflow.	<ul style="list-style-type: none"> • The input has a very low measurement, check the measuring circuit . • With a selected input with a low voltage signal, it is only connected on one side or the input is open. • Not all of the activated supporting points are parameterised. Check if the relevant parameter PN1/PN5, PN2/PN6, PN100/PN140... PN130/PN170 are adjusted correctly • The arithmetic result produces an underflow, see <i>Overflow / Underflow, page 14</i>.
3.	The word HELP lights up in the 7-segment display.	<ul style="list-style-type: none"> • The unit has found an error in the configuration memory. Perform a reset on the default values and reconfigure the unit according to your application.
4.	The display values change in very rough jumps.	<ul style="list-style-type: none"> • During division the measuring value of the divisor is very small, check the measuring circuit.
5.	Program numbers for input parametrisation are not available.	<ul style="list-style-type: none"> • The programming lock is set on an user level, which does not allow the access. • A different sensor type has been parametrised under PN1/PN5, so the desired program number can not be parametrised.
6.	ERR1 lights up in the 7-segment display.	<ul style="list-style-type: none"> • Please contact the manufacturer if errors of this kind occur.
7.	The addressed digital input does not react.	<ul style="list-style-type: none"> • Measure the current of the digital input with a multimeter. It should be between 1 mA and 3 mA.
8.	Program numbers for the analog output PN20...PN22 are not accessible.	<ul style="list-style-type: none"> • The analog output is an option of this device type. If it is not assembled, then the program numbers are not shown.
9.	The device does not react as expected.	<ul style="list-style-type: none"> • If you are not sure if the device has been parametrised before, then follow the steps as written in the next chapter and set it back to its delivery status.