

# M1 – 4-digit digital panel meter in 72x36 mm (BxH) Pt100 2-/3-wire -200°C...850°C / -328°F...1562°F

- red display with -1999...9999 digits (optional green, orange or blue displays)
- minimal installation depth: 100 mm with plug-in terminal
- adjustment via factory default or directly on the sensor signal
- min/max-value recording
- displayed in °C or °F
- display flashing at threshold undercut/ exceedance
- navigation keys for the recall of the min/max-values or for threshold value corrections during operation
- impedance matching
- programming interlock via access code
- protection class IP65 at the front
- plug-in terminal
- optional: 2 relay outputs
- accessories: pc-based configuration-kit PM-TOOL with USB adapter
- on request: devices for working temperatures of -40°C...+70°C



**ORDER NUMBER** **EUR**  
(without options)

## • Pt100 2-/3-wire -200°C...850°C / -328°F...1562°F

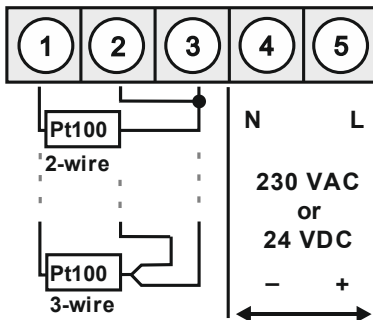

Supply 230 VAC

**M1-6TR4B.030C.570xD** **206.50**

Supply 24 VDC

**M1-6TR4B.030C.770xD** **217.10**

Option:

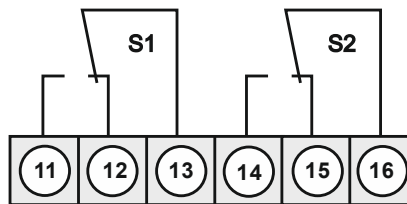

## • Product key options

M	1-	6	T	R	4	B.	0	3	0	C.	5	7	0	x	D	EUR
M	1-	6	T	R	4	B.	0	3	0	C.	7	7	0	x	D	
											D	Dimension/physical unit, customer-specific settings				20.00
											2	2 relay outputs				31.80
											1	without keypad, operation via PC software PM-TOOL				10.60
											X	Other voltage supplies on request!				
											B	Blue				35.00
											G	Green				10.10
											Y	Orange				10.10

State physical unit by order, e.g. °F!

## • Parameterisation software

PC based configuration software PM-Tool for devices without keypad, for a simple adjustment of standard devices, incl. USB-adapter. Programming happens via an interface on the back.

**PM-TOOL-MUSB4** **94.30**

## • Technical data

<b>Dimensions</b>	Housing	B72 x H36 x D71 mm, (incl. plug-in terminal D = 100 mm)
	Panel cut-out	68.0 <sup>+0.7</sup> x 32.0 <sup>+0.6</sup> mm
	Fixing	screw elements for wall thickness up to 3 mm
	Housing material	PC Polycarbonate, black
	Sealing material	EPDM, 65 Shore, black
	Protection class	at the front IP65 standard, at the back IP00
	Weight	approx. 200 g
	Connection	plug-in terminal; wire cross section up to 2.5 mm <sup>2</sup>
<b>Display</b>	Display	4-digit
	Digit height	14 mm
	Segment colour	red (Standard), optional available in green, blue and orange
	Range of display	-1999 to 9999
	Threshold values	optical display flashing
	Overflow	horizontal bars at the top
	Underflow	horizontal bars at the bottom
Display time/Meas. time	0.1 to 10.0 seconds	
<b>Measuring input</b>	Measuring range	-200°C...850°C / -328°F...1562°F
	Measuring error	0.1% of measuring range, ± 1 Digit
	Temperature drift	100 ppm/K
	Measuring time	0.1 ... 10.0 seconds
	Measuring principle	U/F-conversion
	Resolution	approx. 0.1°C or 0.1°F
<b>Output</b>	2x relay outputs	contact voltage 30 VDC/AC, max. 2 A resistive load
	with normally open contact	operating life < 30 mV/< 10 mA – minimum 2.5x10 <sup>6</sup>
		30 VDC / 1 A – minimum 5x10 <sup>5</sup>
		30 VDC / 2 A – minimum 1x10 <sup>5</sup>
<b>Power pack</b>	Supply	230 VAC ±10% (max. 3 VA)
		24 VDC ±10%, galvanic isolated (max. 1 VA)
<b>Memory</b>	EEPROM	Data life ≥ 100 years at 25°C
<b>Ambient conditions</b>	Working temperature	0 to +60°C
	Storing temperature	-20 to +80°C
	Climatic density	relative humidity 0-85% on years average without dew
<b>CE-sign</b>	Conformity to directive 2014/30/EU	
<b>EMV</b>	EN 61326, EN 55011	
<b>Safety standard</b>	According to low voltage directive 2014/35/EU, EN 61010; EN 60664-1	

## Housing:

