

M1 – 4-digit digital panel meter in 96x24 mm (BxH) Pt100 2-/3-wire -200°C...850°C / -328°F...1562°F

- red display of -1999...9999 digits (optional green, orange or blue display)
- minimal installation depth: 57 mm without plug-in terminal
- adjustment via factory default or directly on the sensor signal
- min/max-value recording
- displayed in °C or °F
- display flashing at threshold exceedance / undershooting
- navigation keys for the recall of min/max values or limit value corrections during operation
- impedance matching
- programming interlock via access code
- protection class IP65 at the front
- plug-in terminal
- accessories: pc-based configuration-kit PM-TOOL with USB adapter
- on request: devices for working temperatures of -40°C...+70°C



ORDER NUMBER **EUR**
(without options)

• Pt100 2-/3-wire -200°C...850°C / -328°F...1562°F

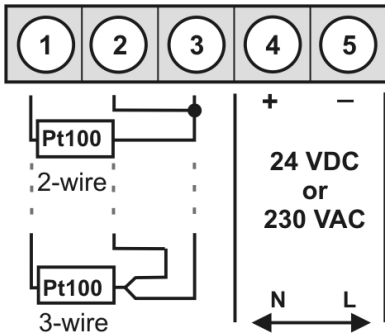

Supply 230 VAC

M1-3TR4B.030C.570xD **190.60**

Supply 24 VDC

M1-3TR4B.030C.770xD **201.20**

• Order key options

M	1-	3	T	R	4	B.	0	3	0	C.	5	7	0	x	D	EUR
M	1-	3	T	R	4	B.	0	3	0	C.	7	7	0	x	D	
											D	Dimension/physical unit, customer-specific settings				20.00
											1	without keypad, operation via PM-TOOL				10.60
											X	Other voltage supplies on request!				
											B	Blue				35.00
											G	Green				10.10
											Y	Orange				10.10

Please state physical unit in order, e.g. °F.

• Parameterisation software

PC based configuration software PM-Tool for devices without keypad, for a simple adjustment of standard devices, incl. USB-adapter. Programming happens via an interface on the back.

PM-TOOL-MUSB4 **94.30**

• Technical data

Dimension	Housing	B96 x H24 x D57 mm (including plug-in terminal, D= 74 mm)	
	Panel cut-out	92.0 ^{+0.8} x 22.2 ^{+0.3} mm	
	Fixing	screw elements for insulation thickness up to 3 mm	
	Housing material	PC Polycarbonate, black	
	Sealing material	EPDM, 65 Shore, black	
	Protection class	at the front IP65 standard, back side IP00	
	Weight	approx. 50 g	
Display	Connection	plug-in terminal; line cross-section up to 2.5 mm ²	
	Display	4-digit	
	Digit height	14 mm	
	Segment colour	red (standard), optional available in green, blue and orange	
	Display range	-1999 to 9999	
	Setpoints	optical display flashing	
	Overflow	horizontal bars at the top	
Measuring input	Underflow	horizontal bars at the bottom	
	Display time/ Measuring time	0.1 to 10.0 seconds	
	Span	-200°C...850°C / -328°F...1562°F	
	Measuring fault	0.1% of measuring range, ± 1 Digit	
	Temperature drift	100 ppm/K	
	Measuring time	0.1 ... 10.0 seconds	
	Measuring principle	U/F-conversion	
Power pack	Resolution	approx. 0.1°C or 0.1°F	
	Supply	230 VAC ±10 % (max. 3 VA) 24 VDC ±10 %, galvanic isolated (max. 1 VA)	
	Memory	EEPROM	
	Ambient conditions	Data life ≥ 100 years at 25°C	
	CE-sign	Working temperature	0 to +60°C
		Storing temperature	-20 to +80°C
		Climatic density	relative humidity 0-85% on years average without dew
EMV	Conformity to directive 2014/30/EU		
	EN 61326, EN 55011		
Safety standard	According to low voltage directive 2014/35/EU, EN 61010; EN 60664-1		

Housing:

